

RENAULT 5 GT TURBO

Groupe A

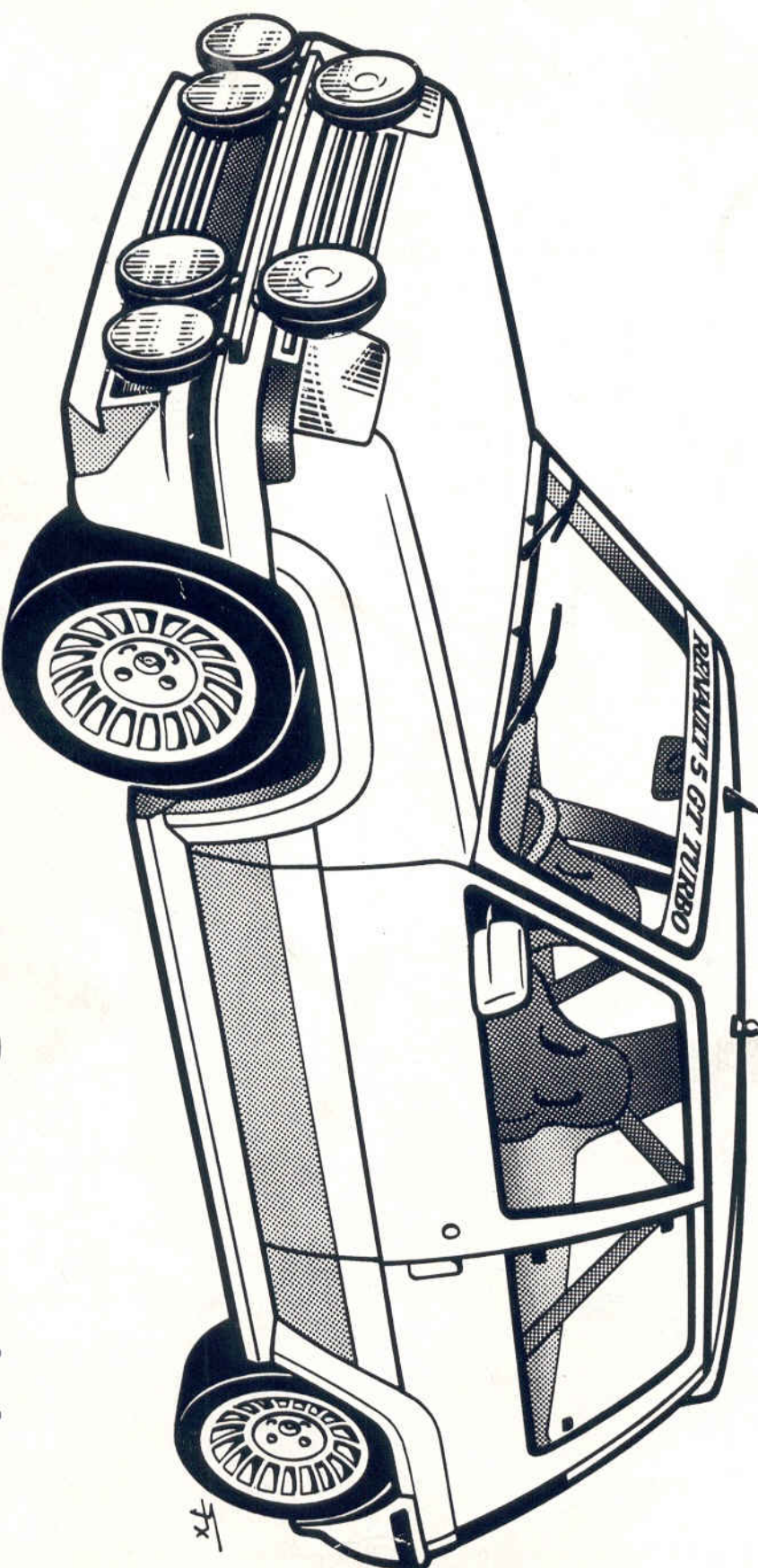

Catalogue de Pièces Compétition

RENAULT 

15-3-89

1 - 77 00 722 393
2 - 77 00 680 167
3 - 77 00 684 429

RENAULT 5 GT TURBO groupe A

13.03

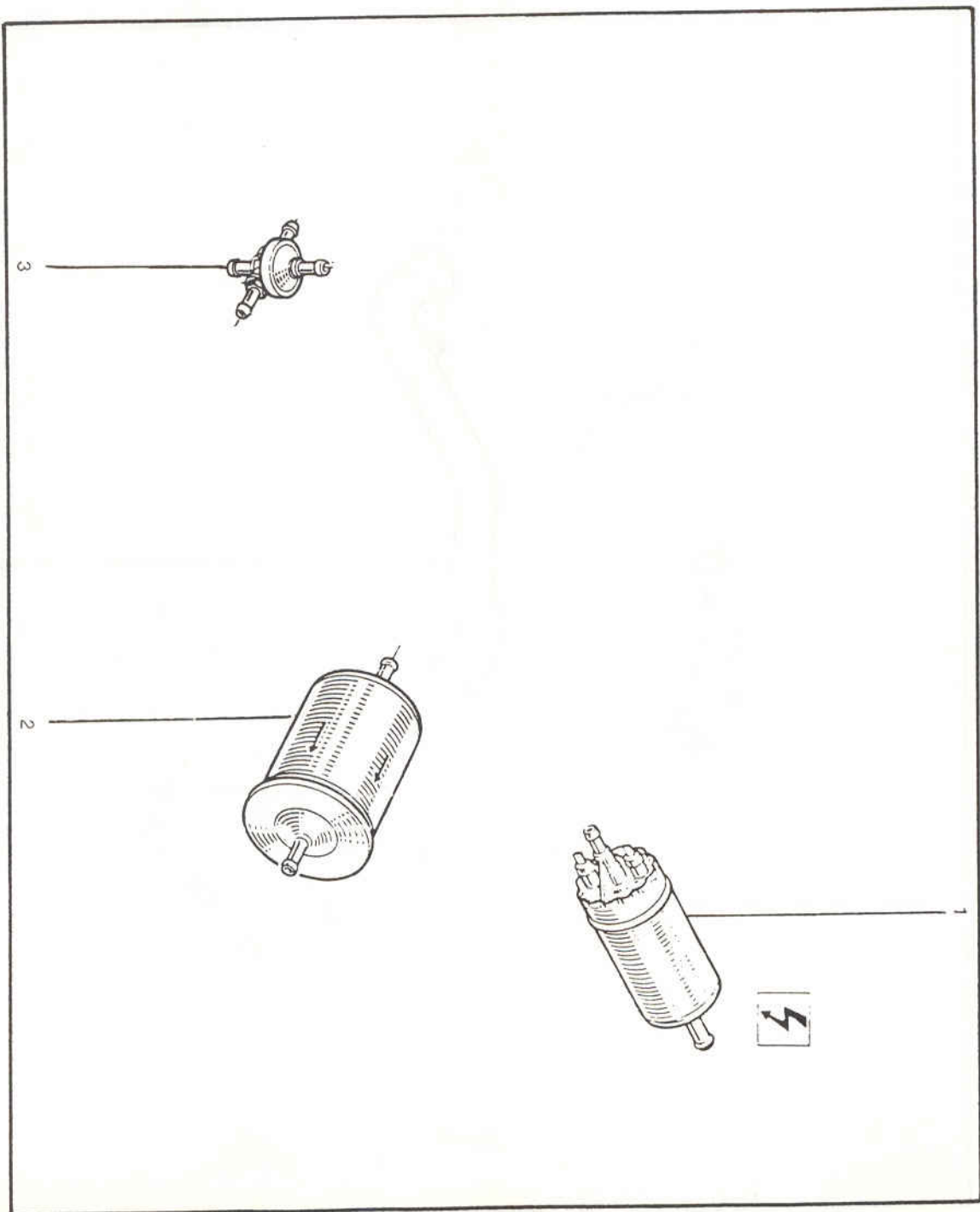
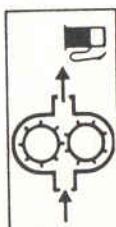

1 - 77 11 068 312 ▲
 2 - 77 11 068 313 ▲
 77 11 068 314 ▲
 Phase 1 ▲
 Phase 2 ▲

RENAULT 5 GT TURBO groupe A

13.30

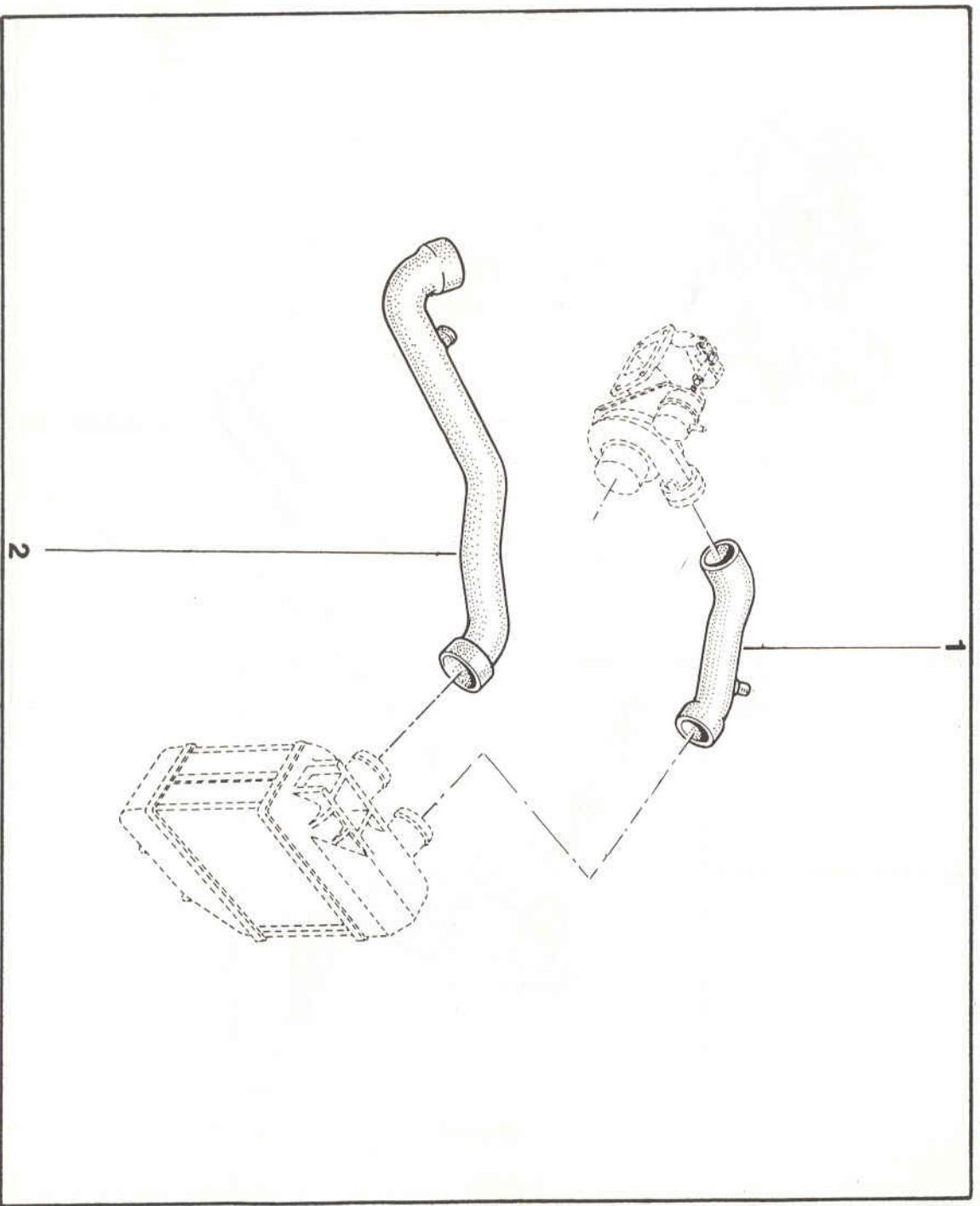

RENAULT 5 GT TURBO groupe A

13.90



- 1 - 60 00 007 918 ▲
- 2 - 60 00 061 089 ▲
- 3 - 77 11 066 872 ▲

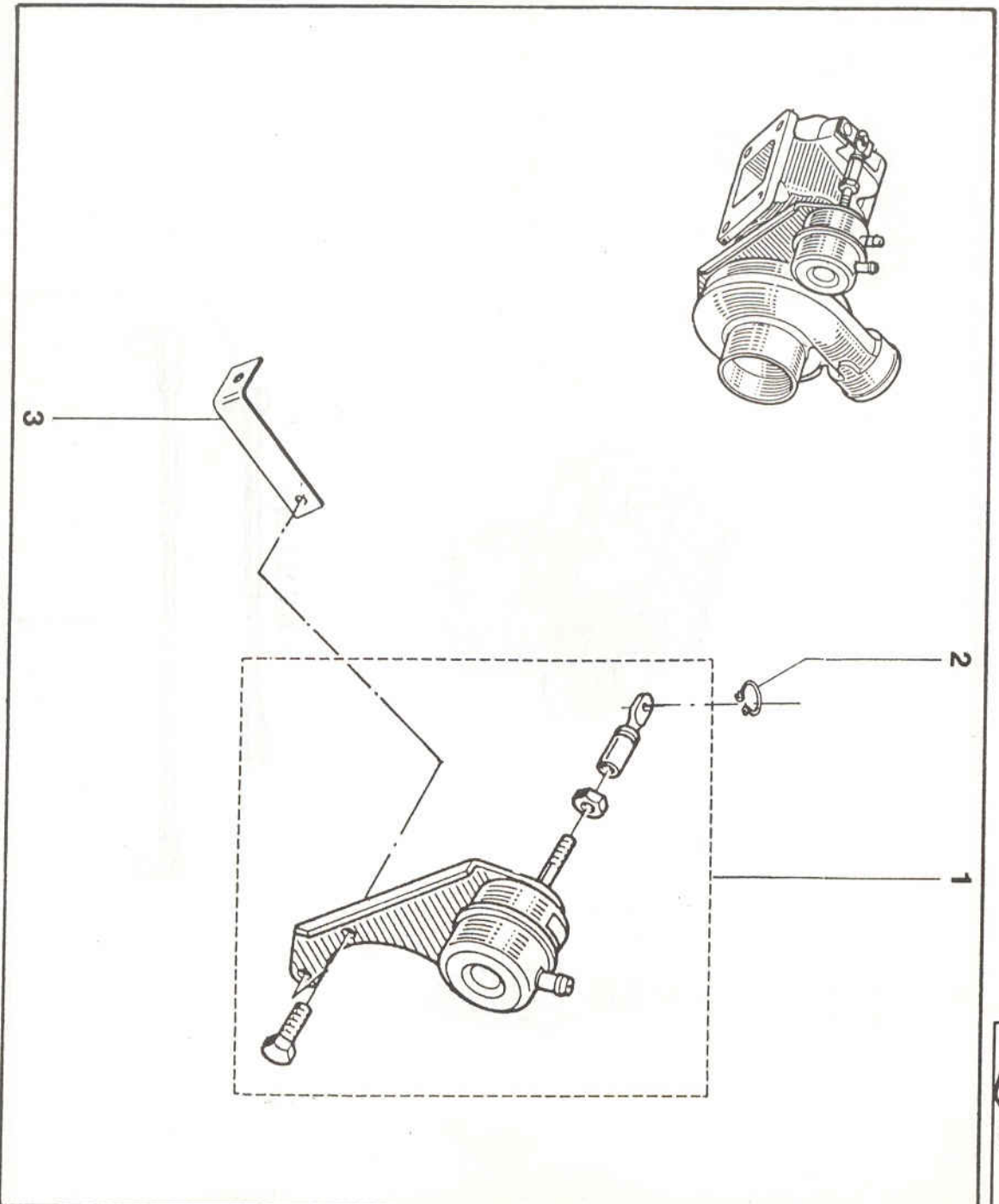

RENAULT 5 GT TURBO groupe A

17.15

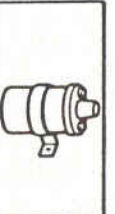

- 1 - 77 11 066 953 ▲
- 2 - 77 11 067 094 ▲
- 3 - 77 11 067 093 ▲
- 4 - 77 11 066 998 ▲
- 77 01 366 084
- N2G
- N3G

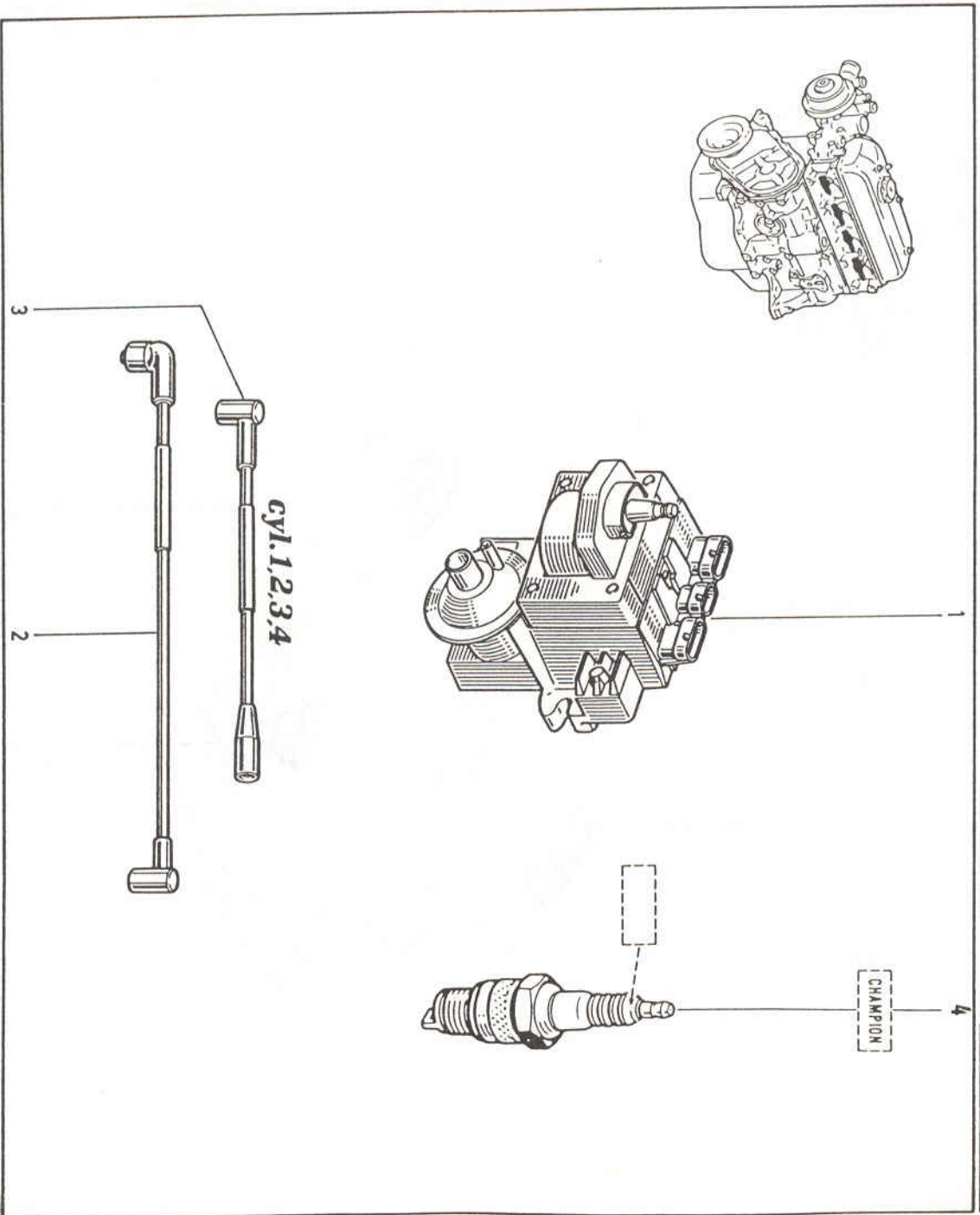

RENAULT 5 GT TURBO groupe A

19.80

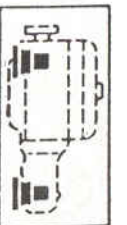

- 1 - 77 11 065 509 ▲
- 2 - 77 11 065 510 ▲
- 3 - 60 01 007 858 ▲

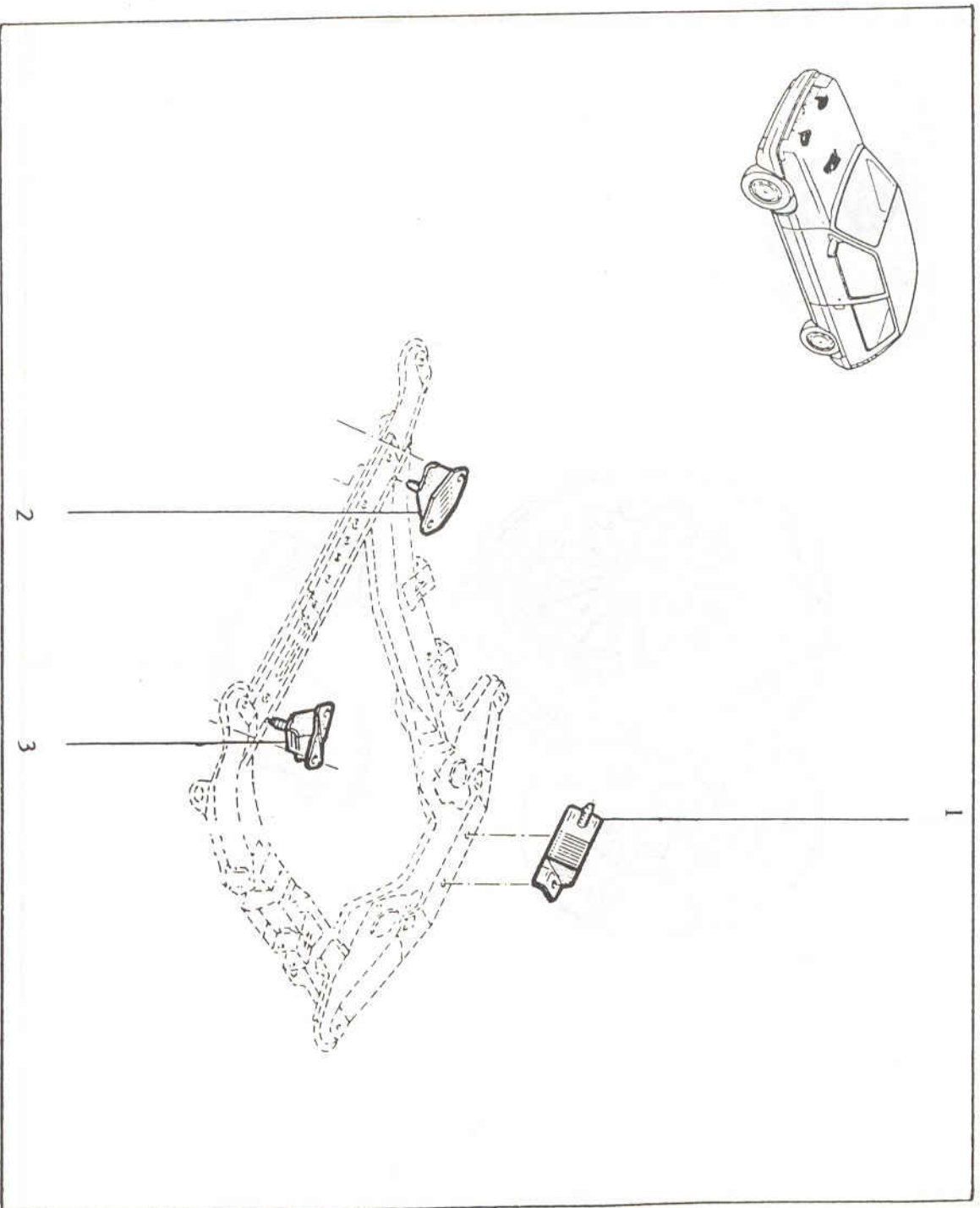

- 1 - 77 11 068 322 ▲
- 2 - 77 11 066 644 ▲ Valéo
- 77 11 068 337 ▲ Sachs
- 3 - 77 11 066 758 ▲

RENAULT 5 GT Turbo groupe A

20.01

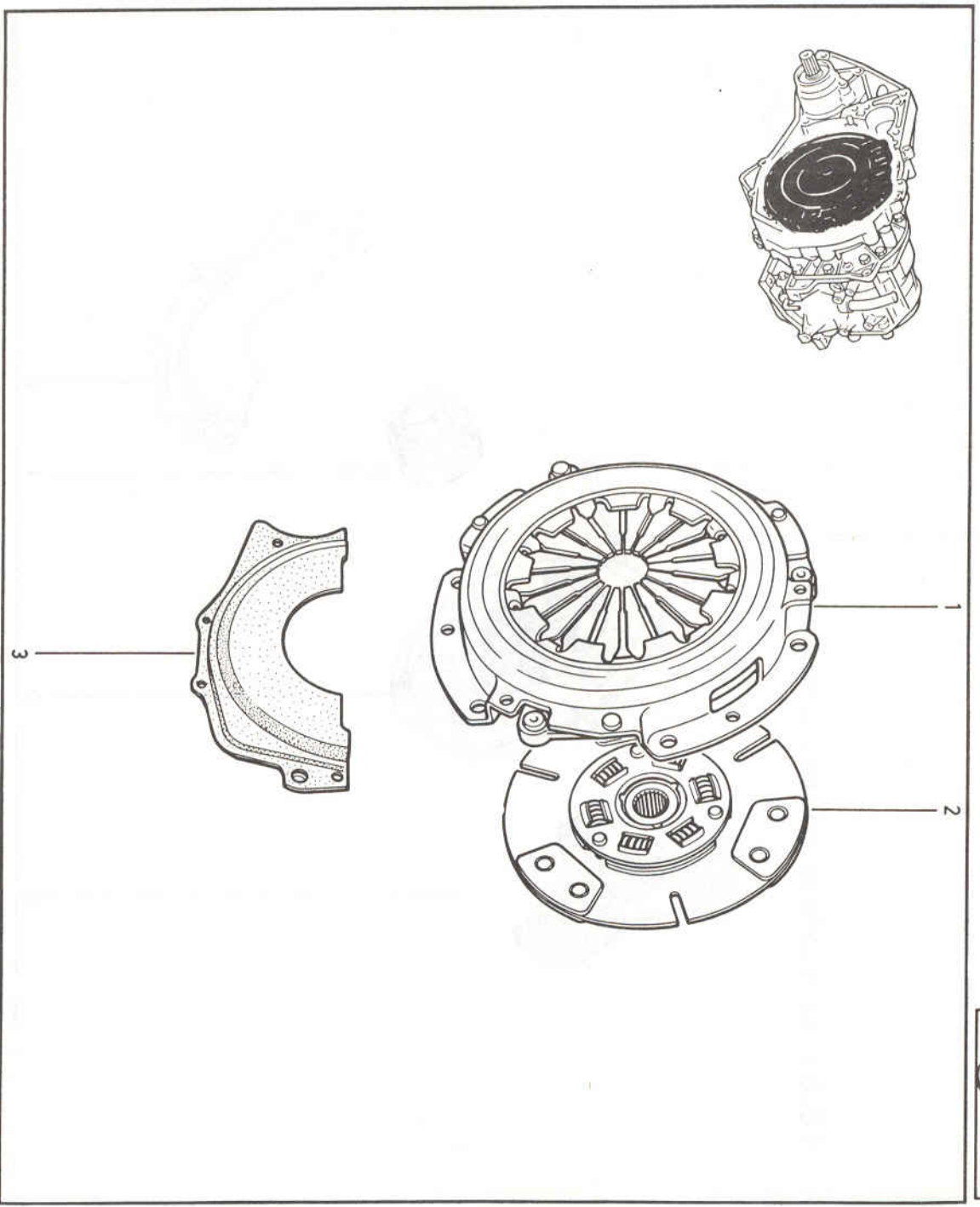

RENAULT 5 GT Turbo groupe A

20.02



- 1 - 77 11 066 962 ▲
- 2 - 77 11 066 586 ▲
- 3 - 77 11 066 587 ▲
- 4 - 77 03 009 104
- 5 - 79 03 057 005
- 6 - 77 11 066 758 ▲

BOITE RS

avec volant moteur pl 10.60

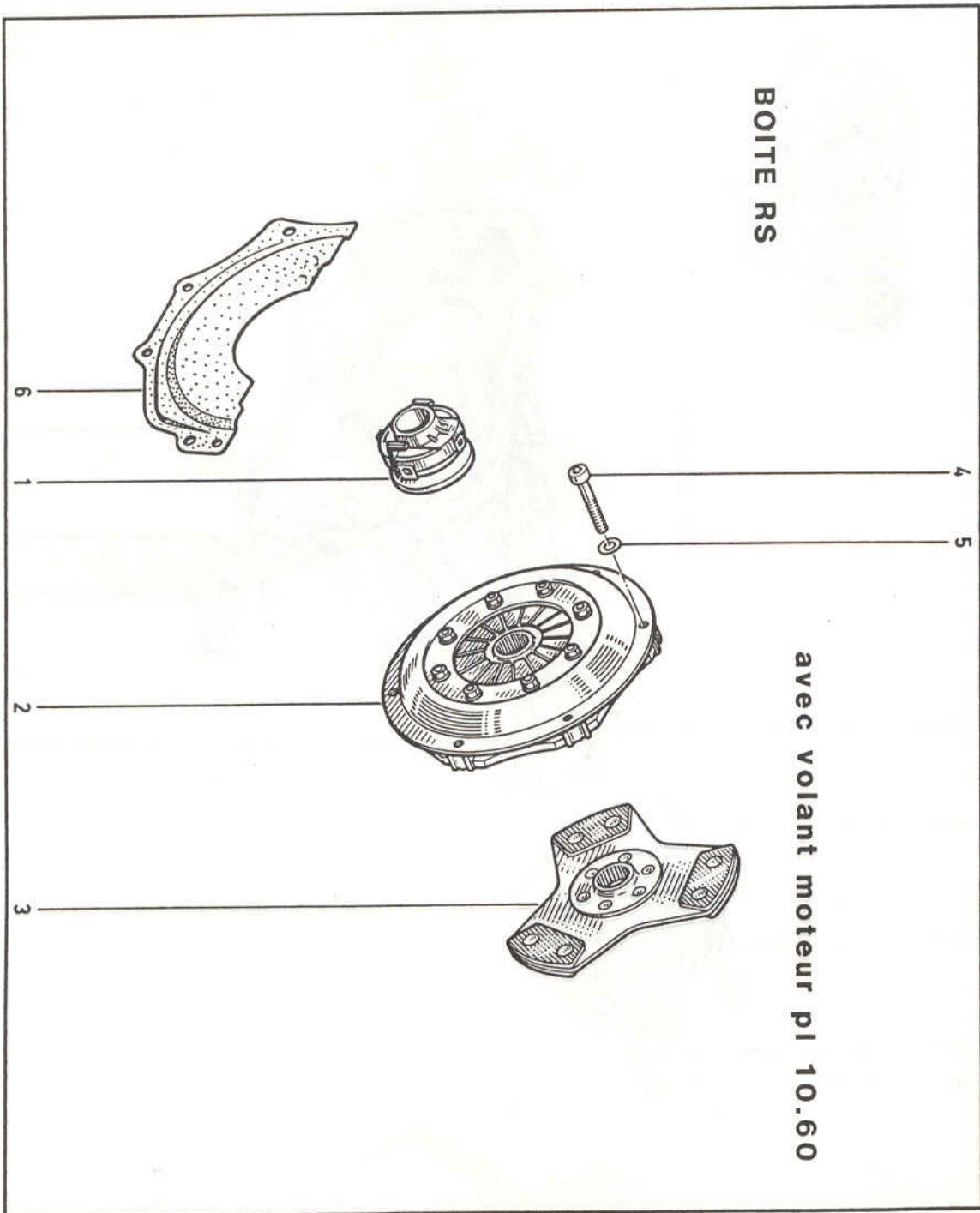

- 1 - 77 11 068 342▲(Axe M.A.R. Ø 23)
- 2 - 77 11 050 940▲
- 3 - 77 11 067 092▲
- 4 - 77 11 067 052▲
- 5 - 77 11 067 053▲
- 6 - 77 04 002 415
- 7 - 77 00 722 801
- 8 - 79 03 053 043
- 9 - 77 03 001 160

RENAULT 5 GT Turbo groupe A

21.20



BOITE RS

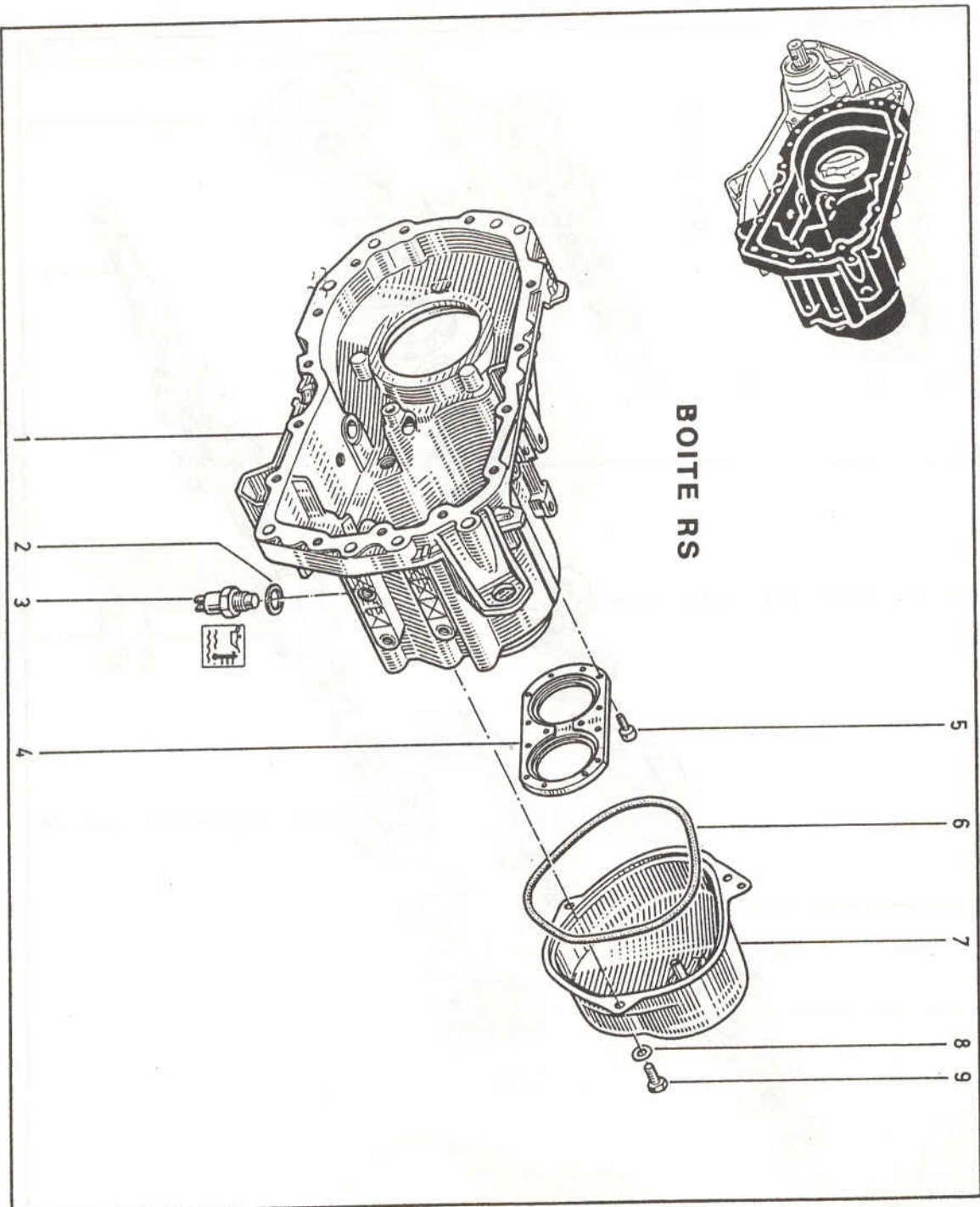

RENAULT 5 GT Turbo groupe A

21.47



- 1 - 77 11 067 047▲ (13X57)
- 77 11 067 048▲ (14X52)
- 77 11 067 340▲ (12X59)
- 2 - 77 11 066 652▲
- 3 - 77 11 066 653▲
- 4 - 77 11 066 654▲
- 5 - 77 11 066 657▲
- 6 - 77 11 066 651▲
- 7 - 77 11 066 661▲
- 8 - 77 11 066 649▲
- 9 - 77 11 066 655▲
- 10 - 77 11 068 338▲ (15 rouleaux)

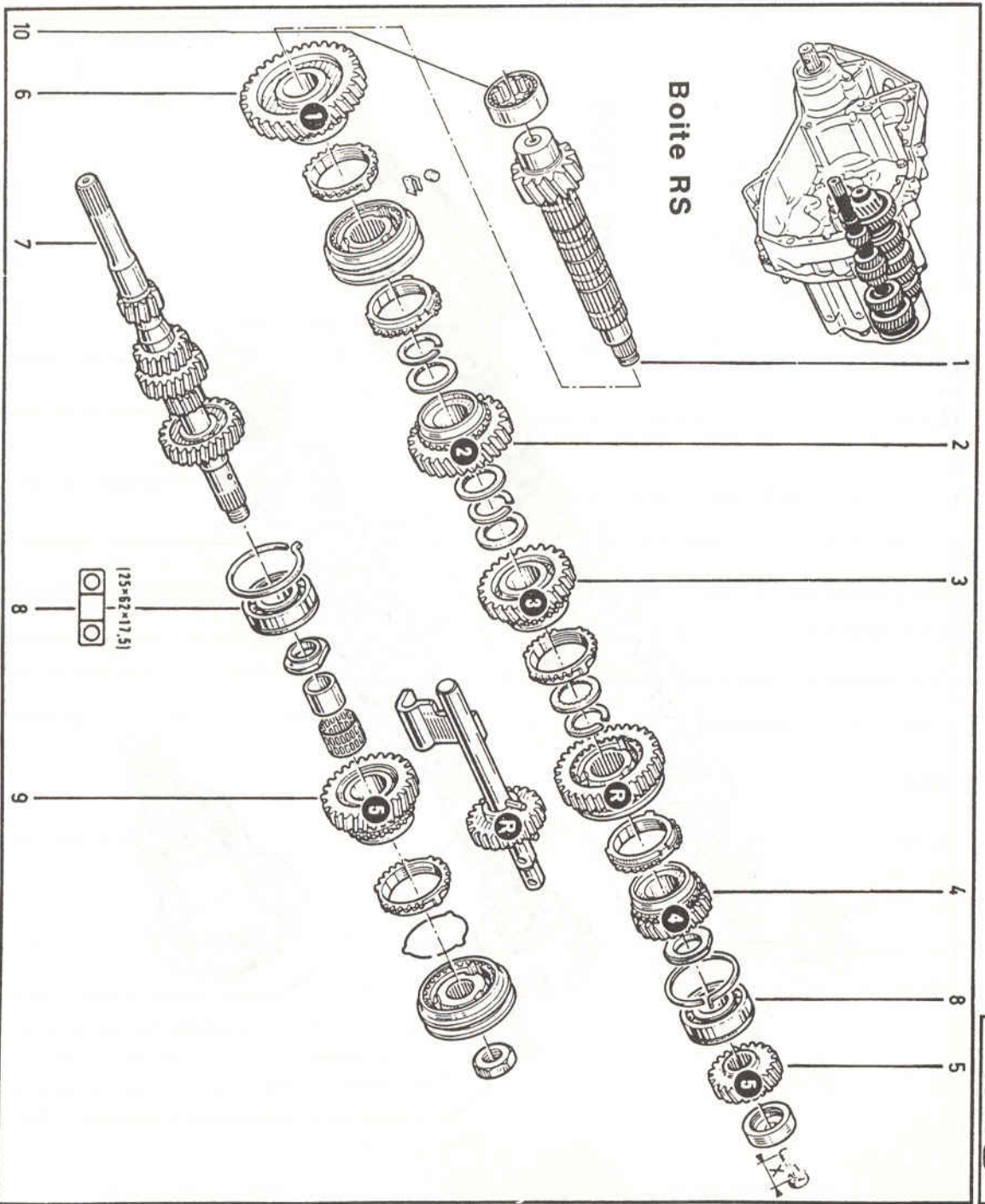

RENAULT 5 GT Turbo groupe A

21.56

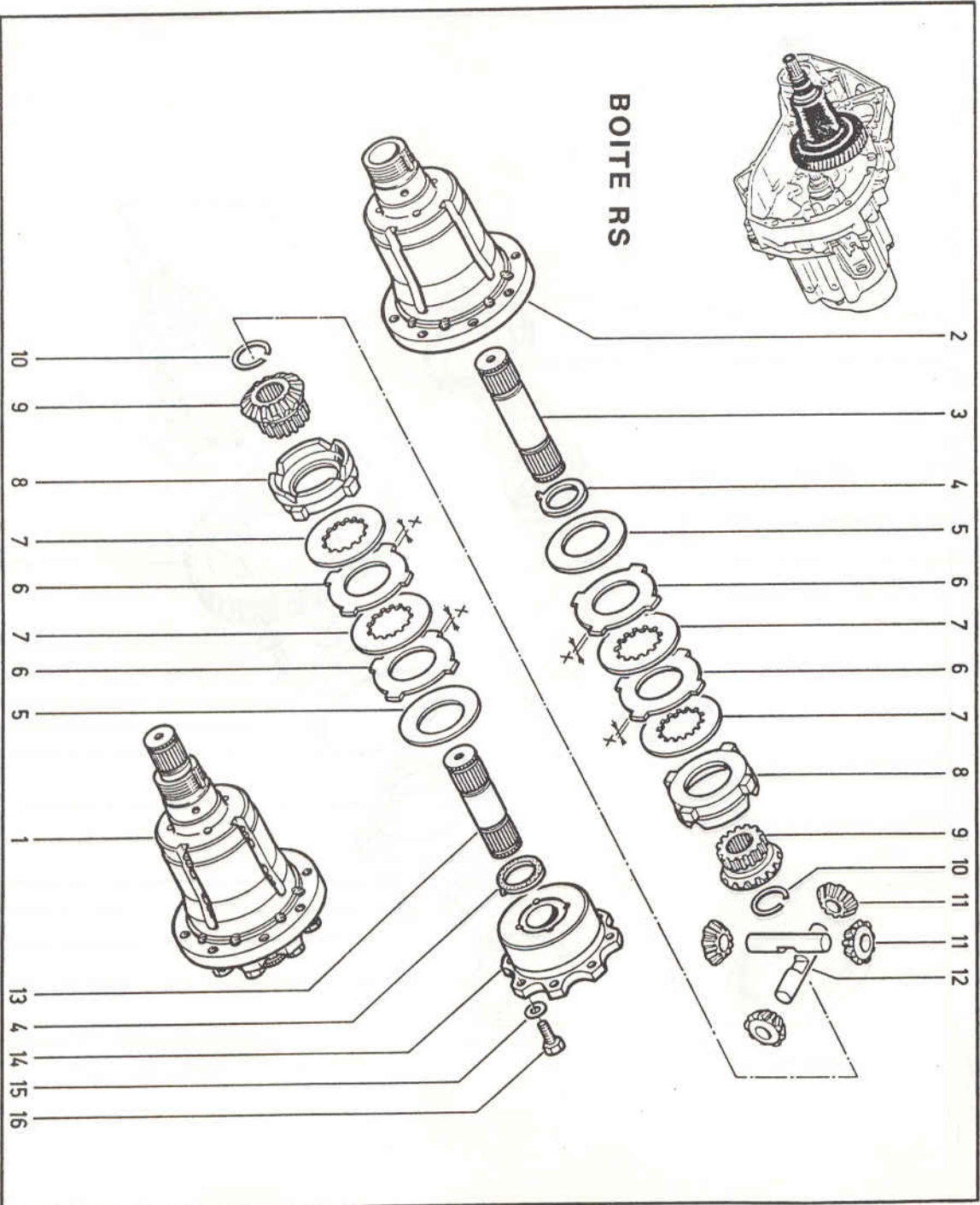

ép : 1,9
ép : 2
ép : 2,1

- 1 - 77 11 067 155 ▲
- 2 - 77 11 067 064 ▲
- 3 - 77 11 067 079 ▲
- 4 - 77 11 064 110 ▲
- 5 - 77 11 067 069 ▲
- 6 - 77 11 067 070 ▲
- 77 11 067 071 ▲
- 77 11 067 072 ▲
- 7 - 77 11 067 073 ▲
- 8 - 77 11 067 074 ▲
- 9 - 77 11 067 075 ▲
- 10 - 77 11 067 080 ▲
- 11 - 77 11 067 076 ▲
- 12 - 77 11 067 077 ▲
- 13 - 77 11 067 078 ▲
- 14 - 77 11 067 065 ▲
- 15 - 79 03 057 005
- 16 - 77 03 001 160 ▲



Service
Compétition

Clients

RENAULT SPORT RALLYE
12, av. F. Sommer
92167 ANTONY Cédex
Téléphone : 46 68 00 38
Télex : 200 941 F.
Télécopieur: 46 68 18 51



Alpine

Service
Compétition

Pièces

RENAULT ALPINE
Z.I. de Rouxmesnil Bouteilles
76370 ROUXMESNIL BOUTEILLES
Téléphone : (35) 82 93 14
(35) 82 33 65
Télex : 180 426 F.

NOTA : Les références suivies du symbole : **▲** sont disponibles à l'adresse ci-dessus.
Pour toutes autres références, s'approvisionner auprès de votre concessionnaire ou agent RENAULT.

RENAULT 5 GT Turbo groupe A

21.57

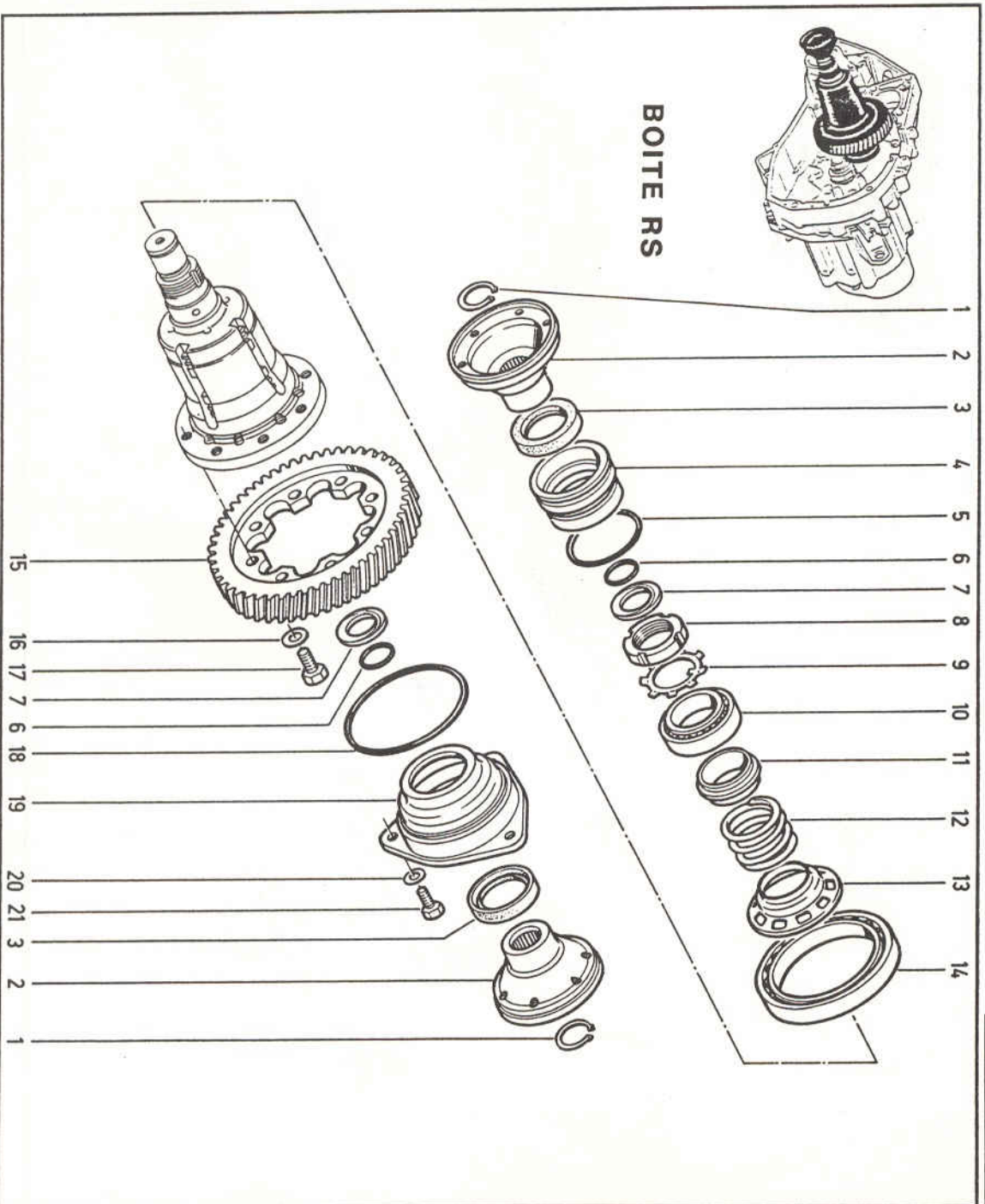

- 1 - 77 11 067 081 ▲
- 2 - 77 11 067 089 ▲
- 3 - 77 11 067 088 ▲
- 4 - 77 11 067 084 ▲
- 5 - 77 11 067 085 ▲
- 6 - 77 11 067 082 ▲
- 7 - 77 11 067 083 ▲
- 8 - 77 11 067 066 ▲
- 9 - 77 11 067 067 ▲
- 10 - 77 03 090 361
- 11 - 77 03 090 973
- 12 - 77 05 015 166
- 13 - 77 00 680 811
- 14 - 77 03 090 362
- 15 - 77 11 067 049 ▲(13X57)
- 77 11 067 050 ▲(14X52)
- 77 11 067 339 ▲(12X59)
- 16 - 77 11 066 668 ▲
- 17 - 77 11 066 665 ▲
- 18 - 77 11 067 087 ▲
- 19 - 77 11 067 086 ▲
- 20 - 79 03 057 105
- 21 - 77 03 001 160

I - 77 11 066 820 ▲

RENAULT 5 GT Turbo groupe A

21.60

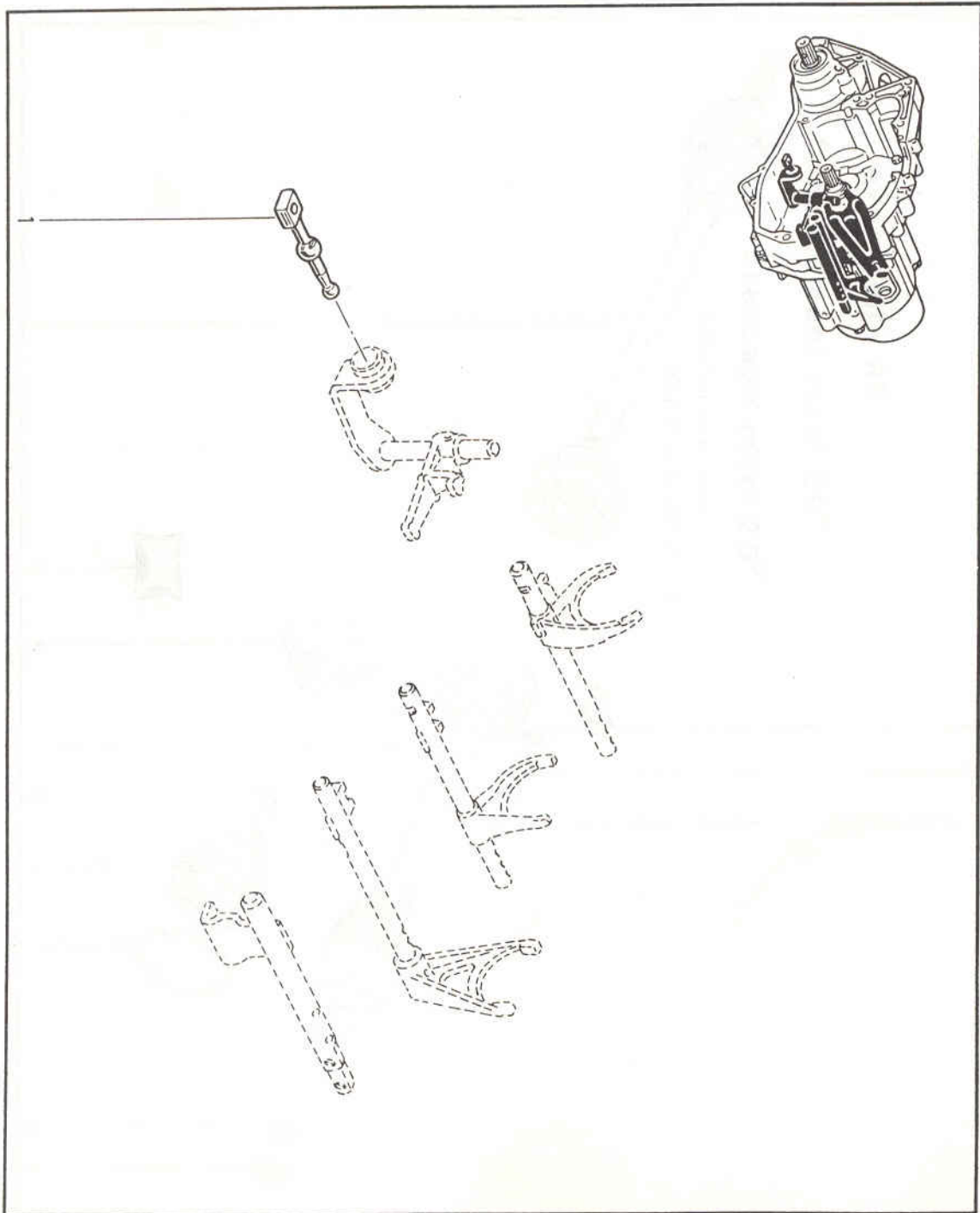

RENAULT 5 GT Turbo groupe A

29.01

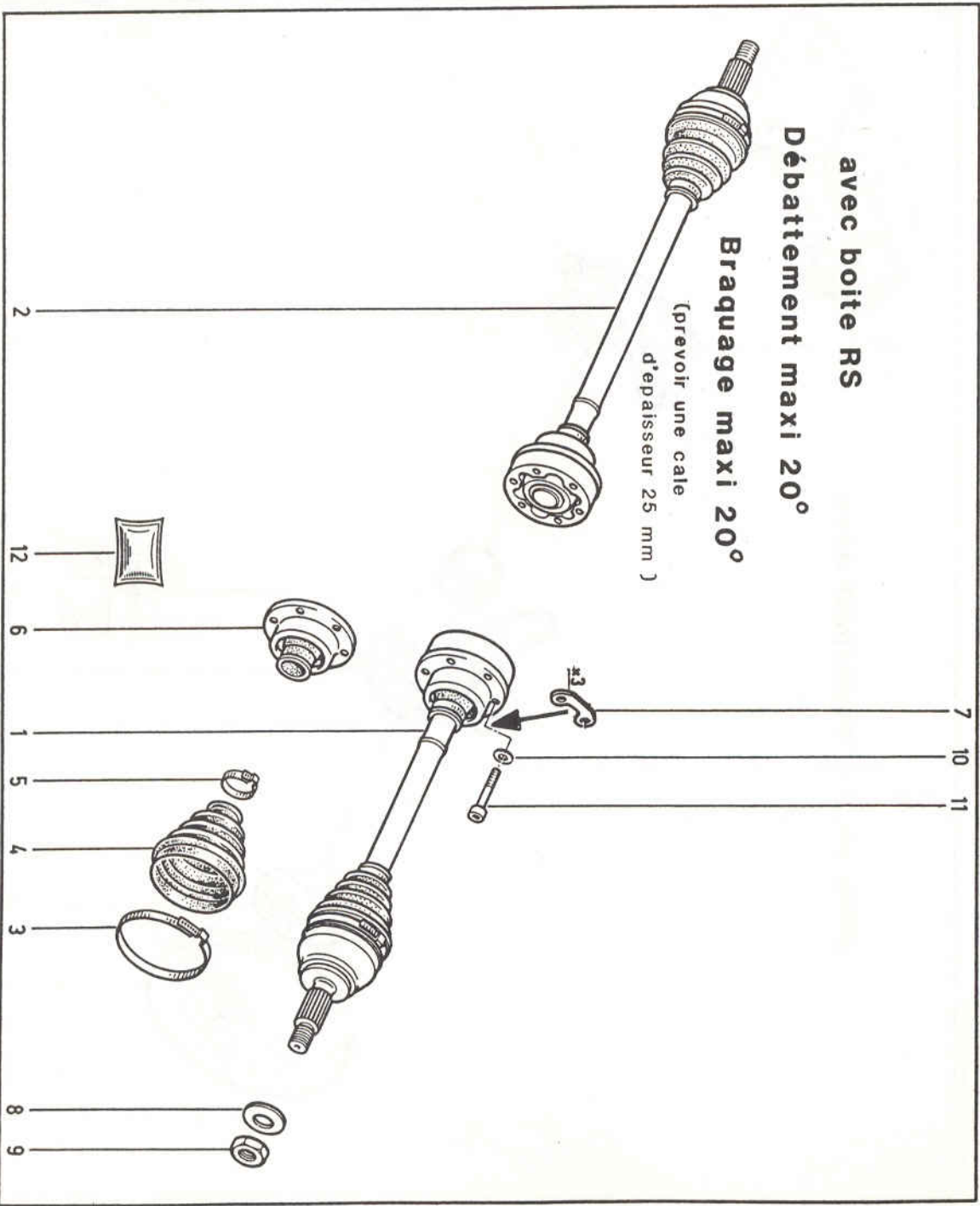

- 1 - 77 11 067 479 ▲
- 2 - 77 11 067 480 ▲
- 3 - 77 11 066 630 ▲
- 4 - 77 11 067 152 ▲
- 5 - 77 11 066 631 ▲
- 6 - 77 11 067 153 ▲
- 7 - 77 11 067 332 ▲
- 8 - 77 03 058 047
- 9 - 77 11 066 736 ▲
- 10 - 79 03 057 005
- 11 - 77 11 051 266 ▲
- 12 - 77 11 066 633 ▲

RENAULT 5 GT Turbo groupe A

31.40



avec transmissions de serie

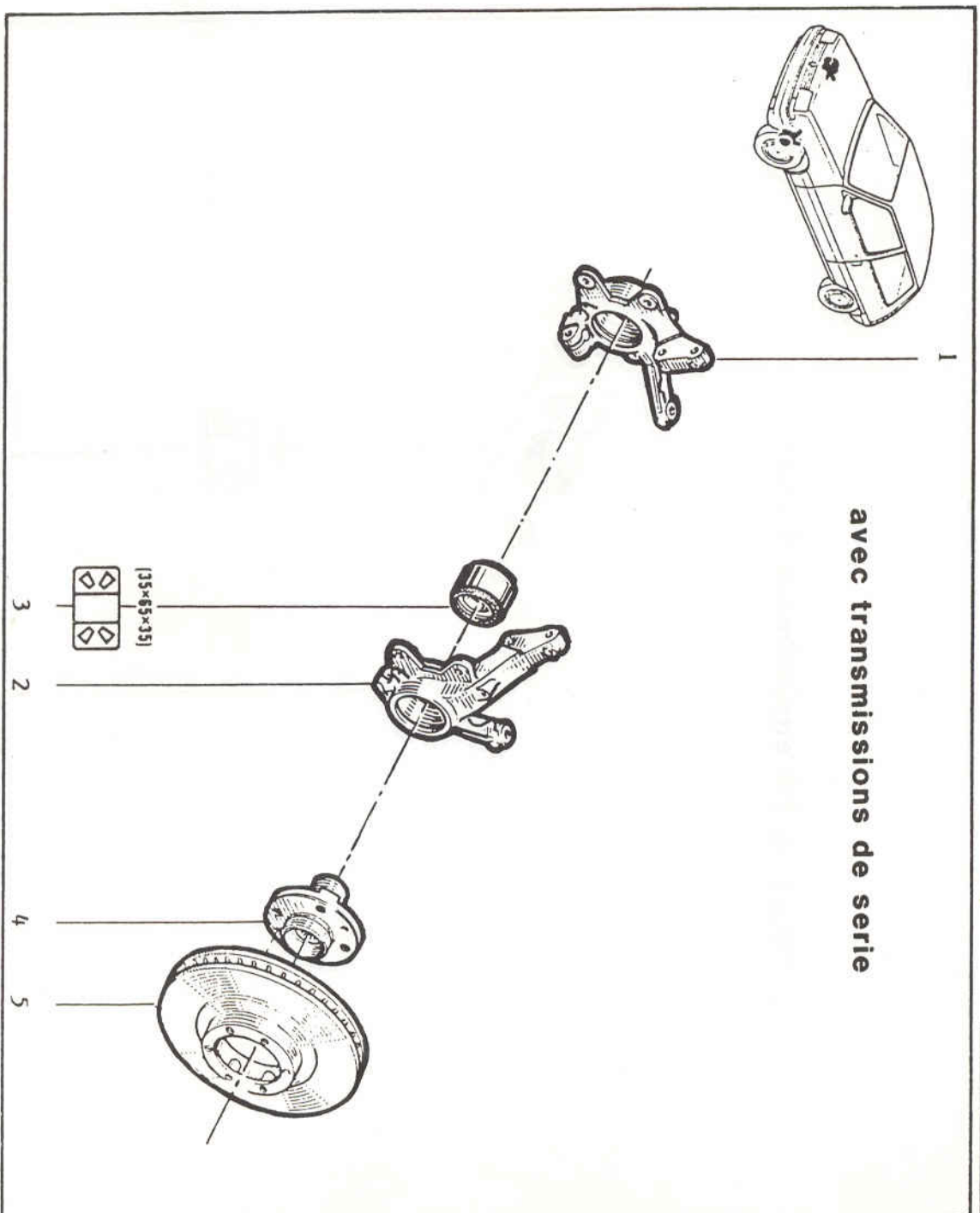

- 1 77 00 677 034
- 2 77 00 677 033
- 3 77 11 066 592 ▲
- 4 77 11 065 983 ▲
- 5 77 00 756 572 ▲

- 1 - 77 11 066 944 ▲
- 2 - 77 03 065 119
- 3 - 77 00 679 315

RENAULT 5 GT TURBO groupe A

36.00

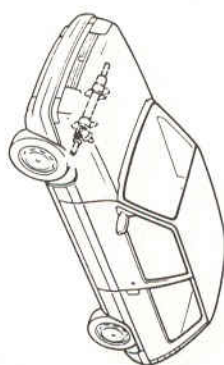
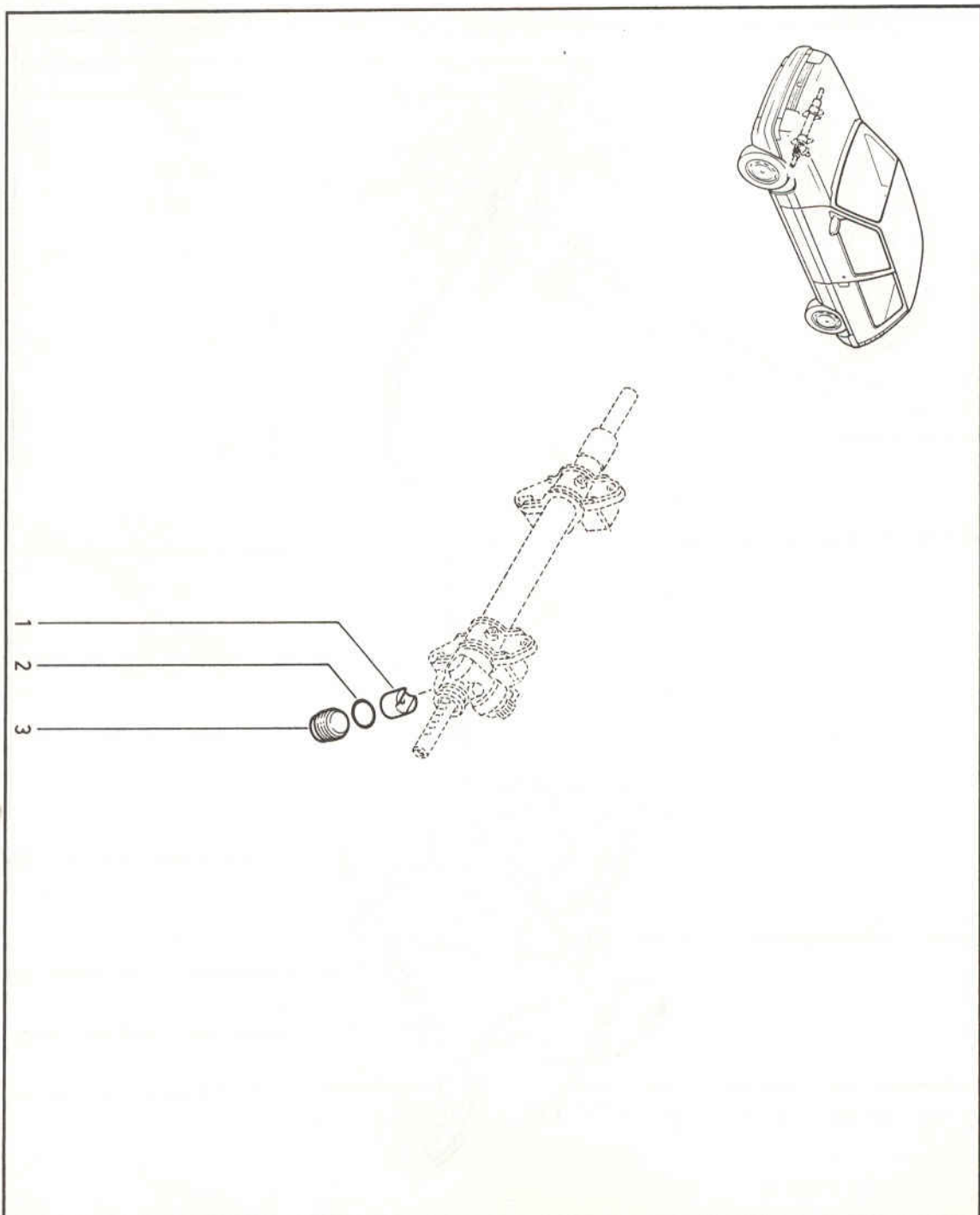

- 1 - 77 11 066 944 ▲
- 2 - 77 03 065 119
- 3 - 77 00 679 315

RENAULT 5 GT TURBO groupe A

36.00

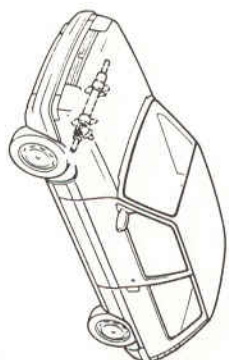
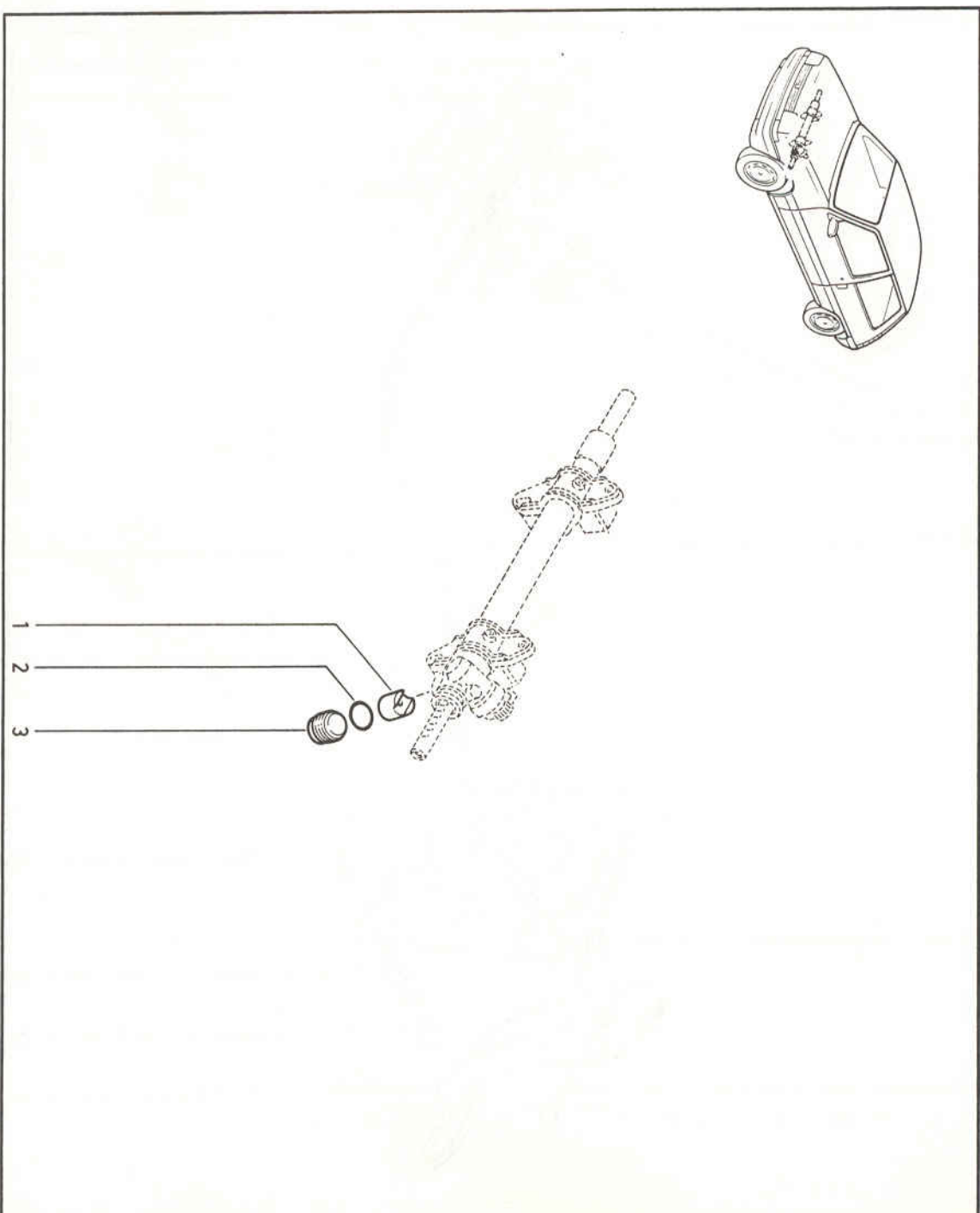

- 1 - 77 11 066 944 ▲
- 2 - 77 03 065 119
- 3 - 77 00 679 315

RENAULT 5 GT TURBO groupe A

36.00

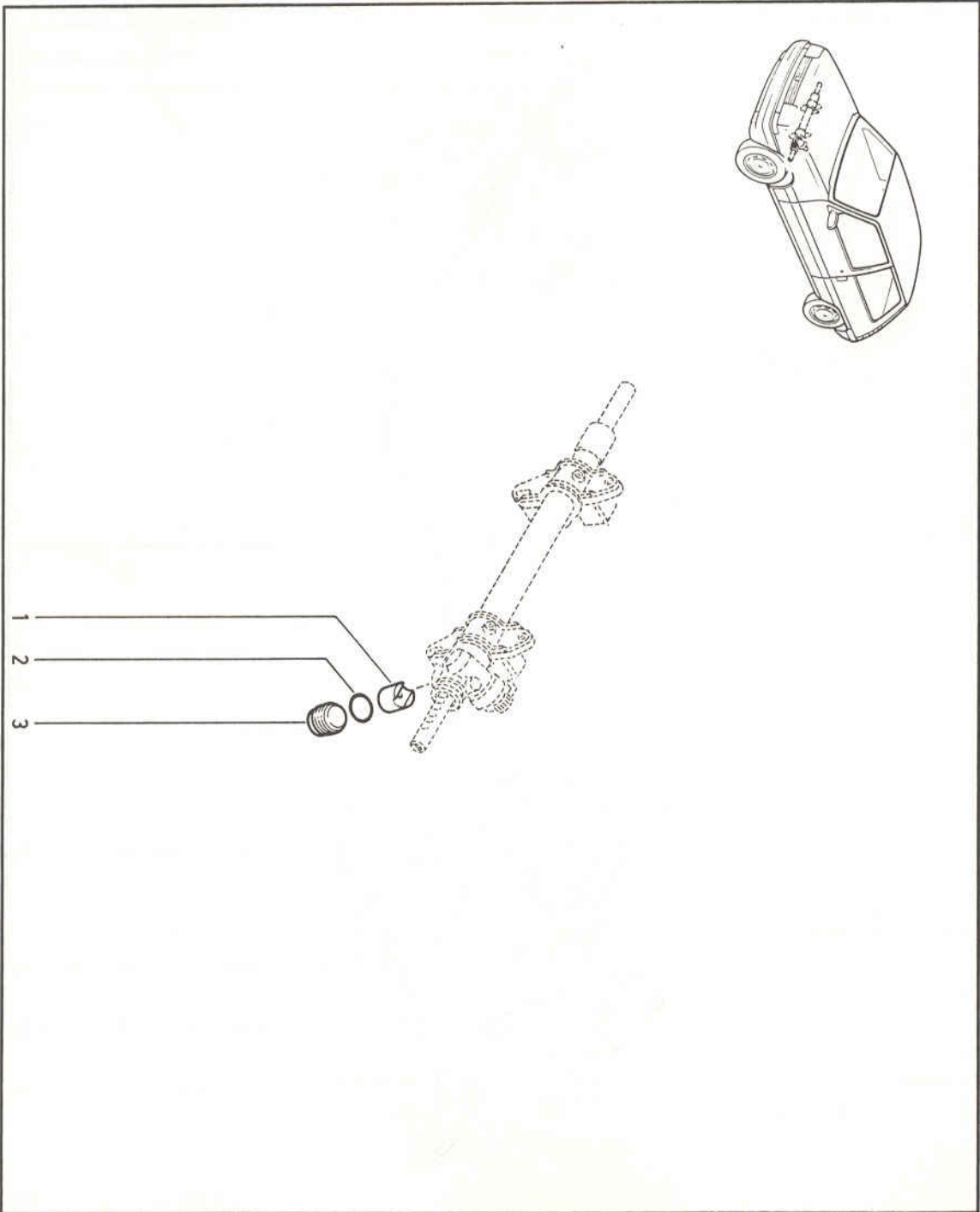

RENAULT 5 GT TURBO groupe A

37.20

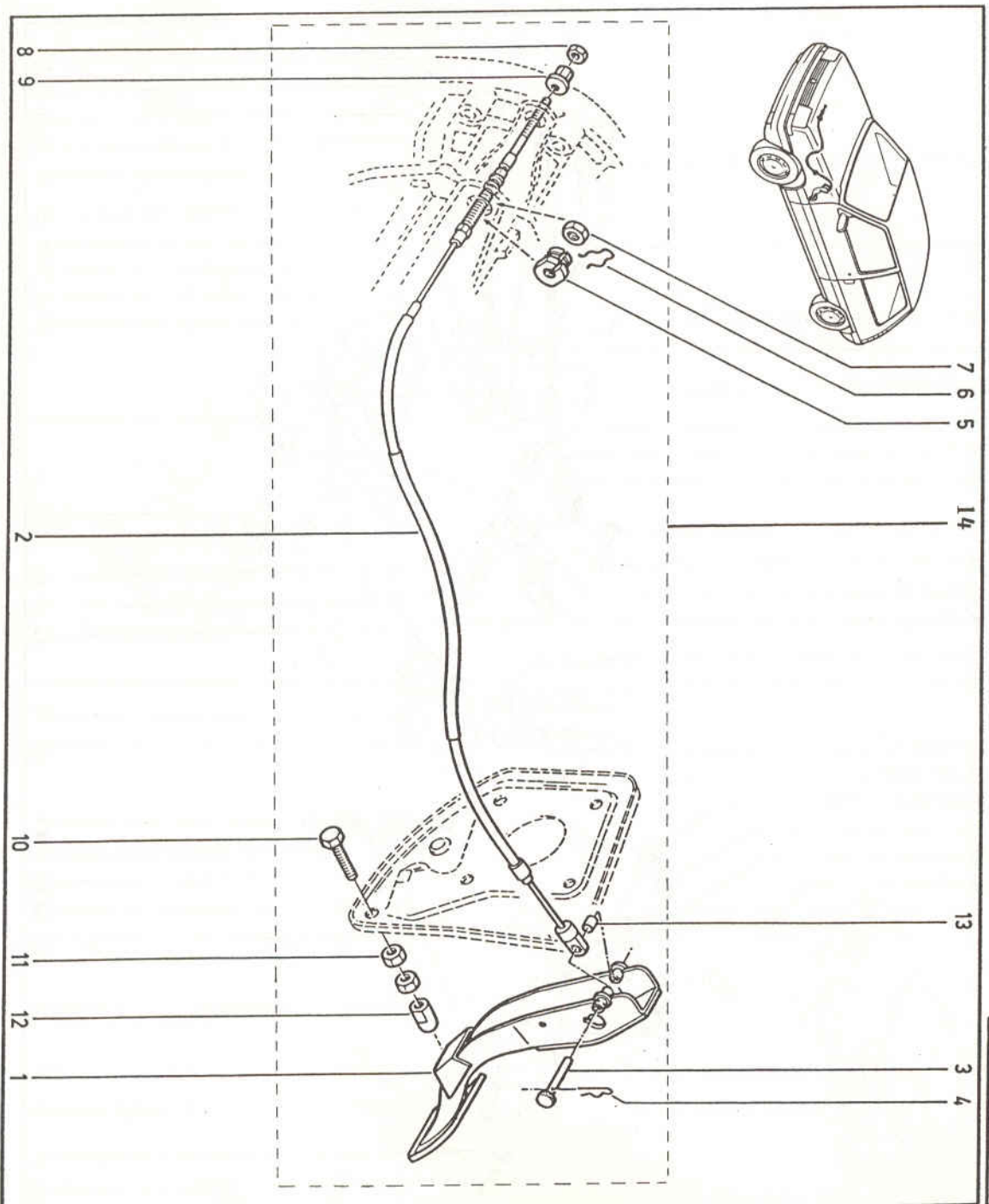

- 1 - 77 11 067 120 ▲
- 2 - 77 11 067 118 ▲
- 3 - 77 11 067 121 ▲
- 4 - 77 03 068 011 .
- 5 - 77 11 066 591 ▲
- 6 - 77 03 066 257 ▲
- 7 - 77 11 051 342 ▲
- 8 - 79 03 032 012 ▲
- 9 - 77 11 067 119 ▲
- 10 - 77 03 001 162 ▲
- 11 - 77 11 051 324 ▲
- 12 - 77 11 067 122 ▲
- 13 - 77 11 067 325 ▲
- 14 - 60 00 008 480 ▲

RENAULT 5 GT Turbo groupe A

38.02

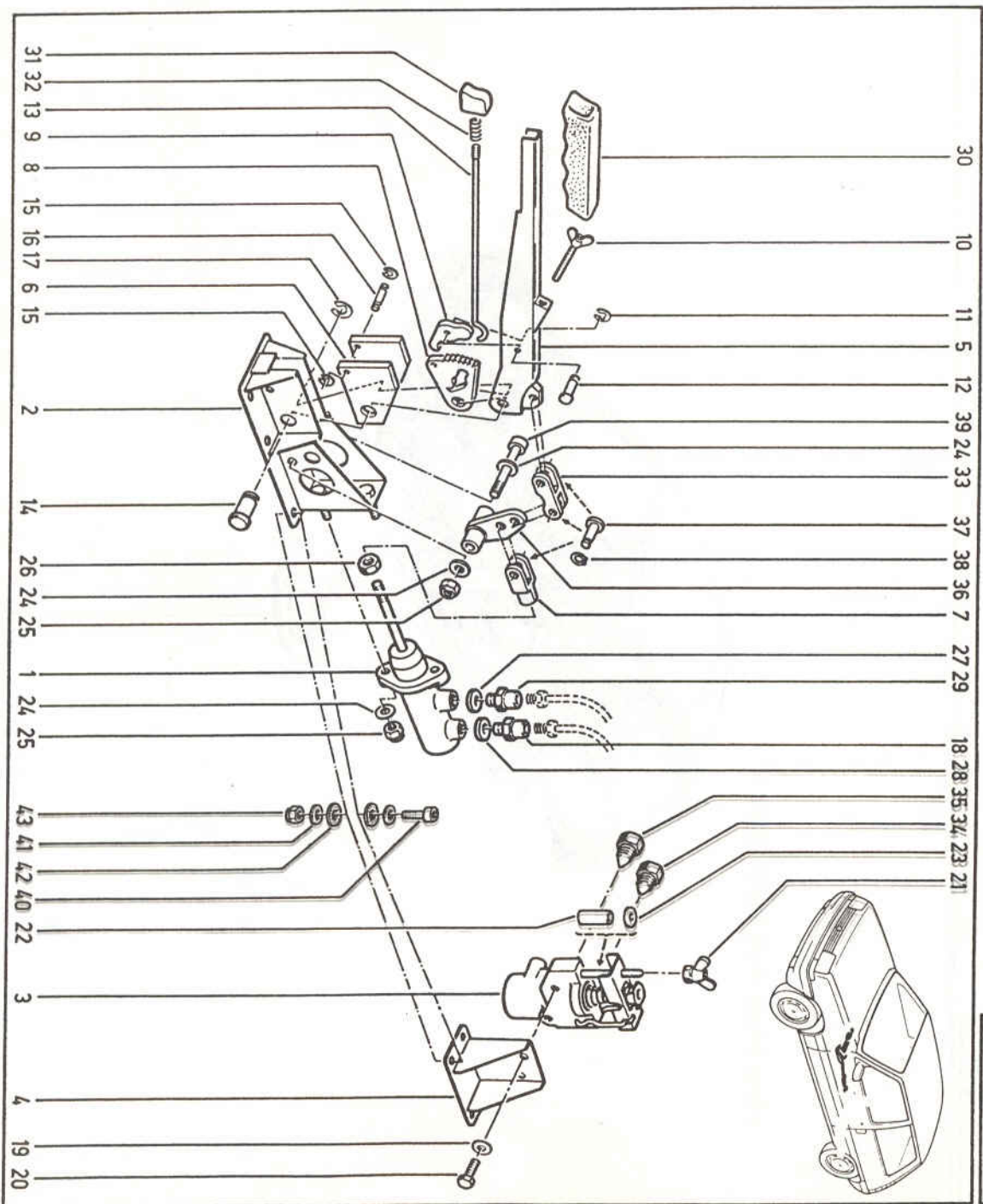

- 1 - 77 11 067 046 ▲
- 2 - 77 11 067 109 ▲
- 3 - 77 11 066 811 ▲
- 4 - 77 11 066 812 ▲
- 5 - 77 11 066 783 ▲
- 6 - 77 11 066 791 ▲
- 7 - 77 11 067 108 ▲
- 8 - 77 00 662 771 ▲
- 9 - 77 00 662 770 ▲
- 10 - 77 11 066 788 ▲
- 11 - 77 03 066 150 ▲
- 12 - 77 03 050 033 ▲
- 13 - 77 00 662 784 ▲
- 14 - 77 11 066 793 ▲
- 15 - 77 03 066 151 ▲
- 16 - 77 11 066 792 ▲
- 17 - 77 03 066 162 ▲
- 18 - 77 11 066 845 ▲
- 19 - 77 03 053 074 ▲
- 20 - 77 03 001 236 ▲
- 21 - 77 11 066 810 ▲
- 22 - 77 11 066 806 ▲
- 23 - 77 03 053 172 ▲
- 24 - 77 01 402 068 ▲
- 25 - 77 03 034 037 ▲
- 26 - 79 03 032 072 ▲
- 27 - 60 00 002 035 ▲
- 28 - 60 00 002 036 ▲
- 29 - 77 11 066 846 ▲
- 30 - 77 00 662 742 ▲
- 31 - 77 00 662 741 ▲
- 32 - 77 00 662 781 ▲
- 33 - 77 11 067 111 ▲
- 34 - 77 11 065 266 ▲
- 35 - 77 11 066 825 ▲
- 36 - 77 11 067 110 ▲
- 37 - 77 03 050 040 ▲
- 38 - 77 03 066 153 ▲
- 39 - 77 03 009 092 ▲
- 40 - 77 03 009 005 ▲
- 41 - 77 01 402 061 ▲
- 42 - 77 03 061 072 ▲
- 43 - 77 11 051 326 ▲

RENAULT 5 GT TURBO groupe A

40.00



- 1 - 77 11 066 886 ▲
77 11 068 336 ▲renforcée et
arceau 6 points acier soudé
- 2 - 77 11 066 940 ▲(X = 5)
77 11 066 941 ▲(X = 15)

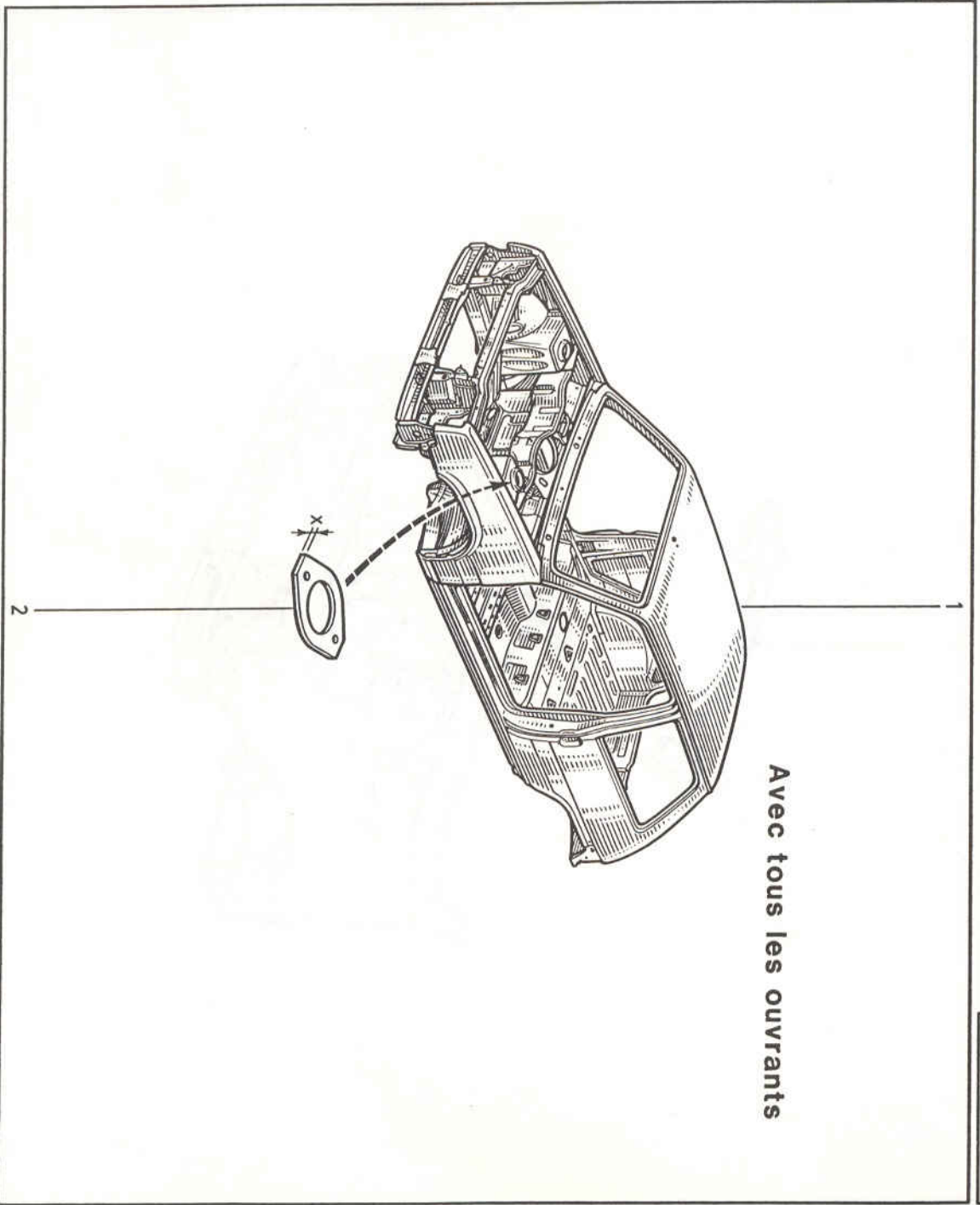

RENAULT 5 GT TURBO groupe A

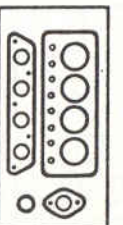

10.10

- 1 - 60 01 006 830 ▲ Kit 1 (\emptyset 76)
ép : 1,8mm
- 2 - 77 11 067 335 ▲ Kit 2 (\emptyset 76,6)
ép : 1,45mm

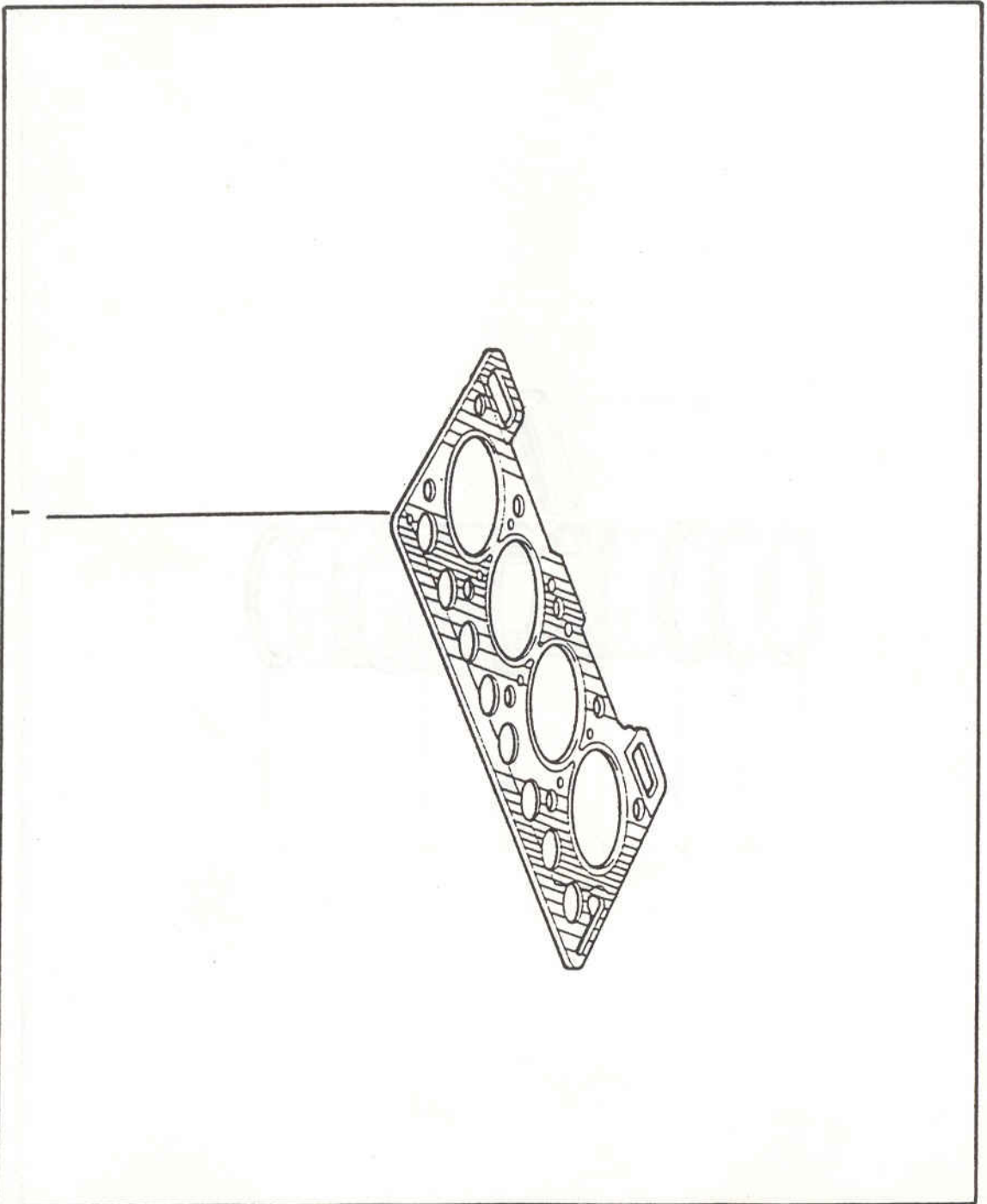

1 - 77 11 066 640 (MATTER) ▲

RENAULT 5 GT TURBO groupe A

40.01

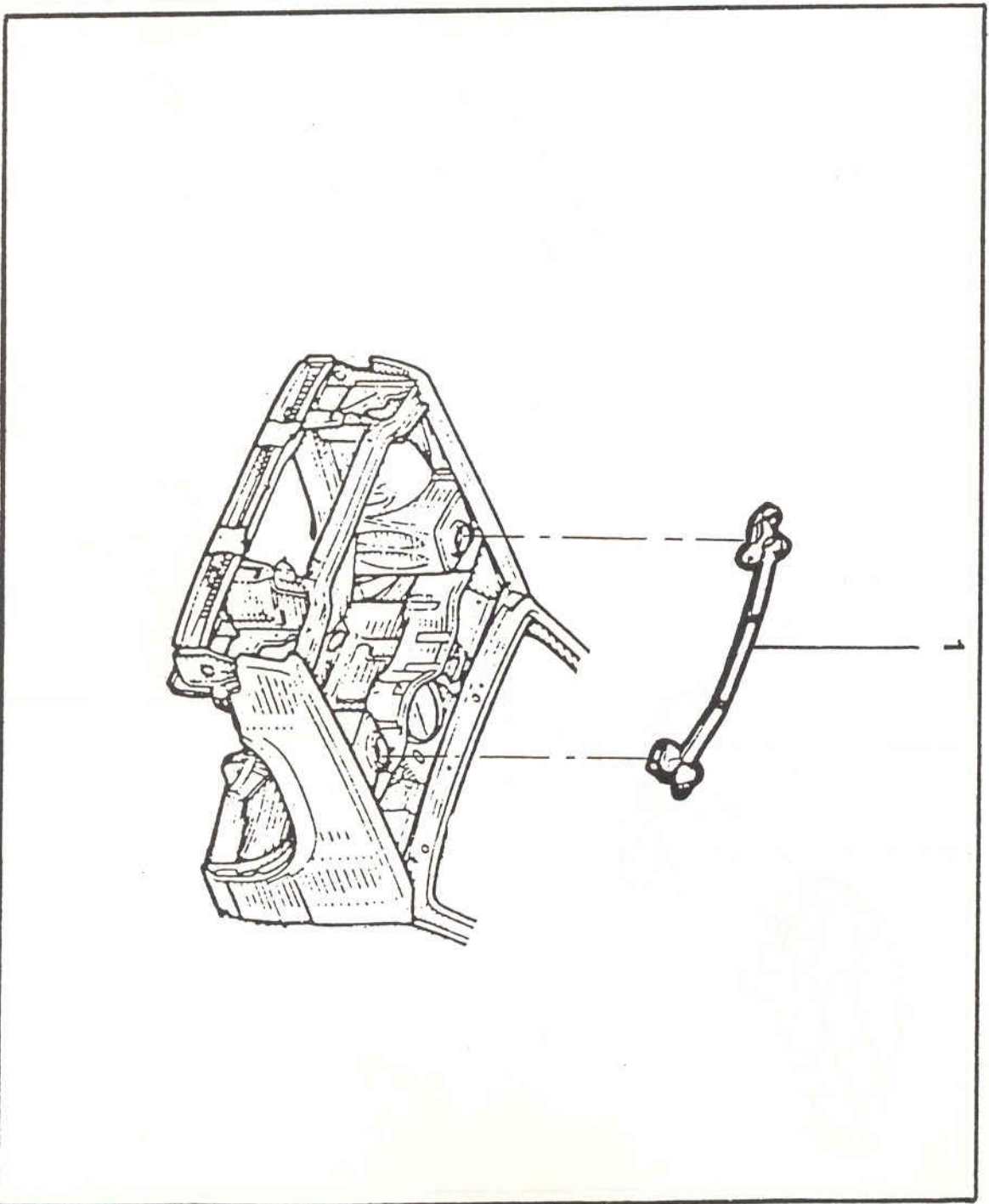

RENAULT 5 GT TURBO groupe A

48.01

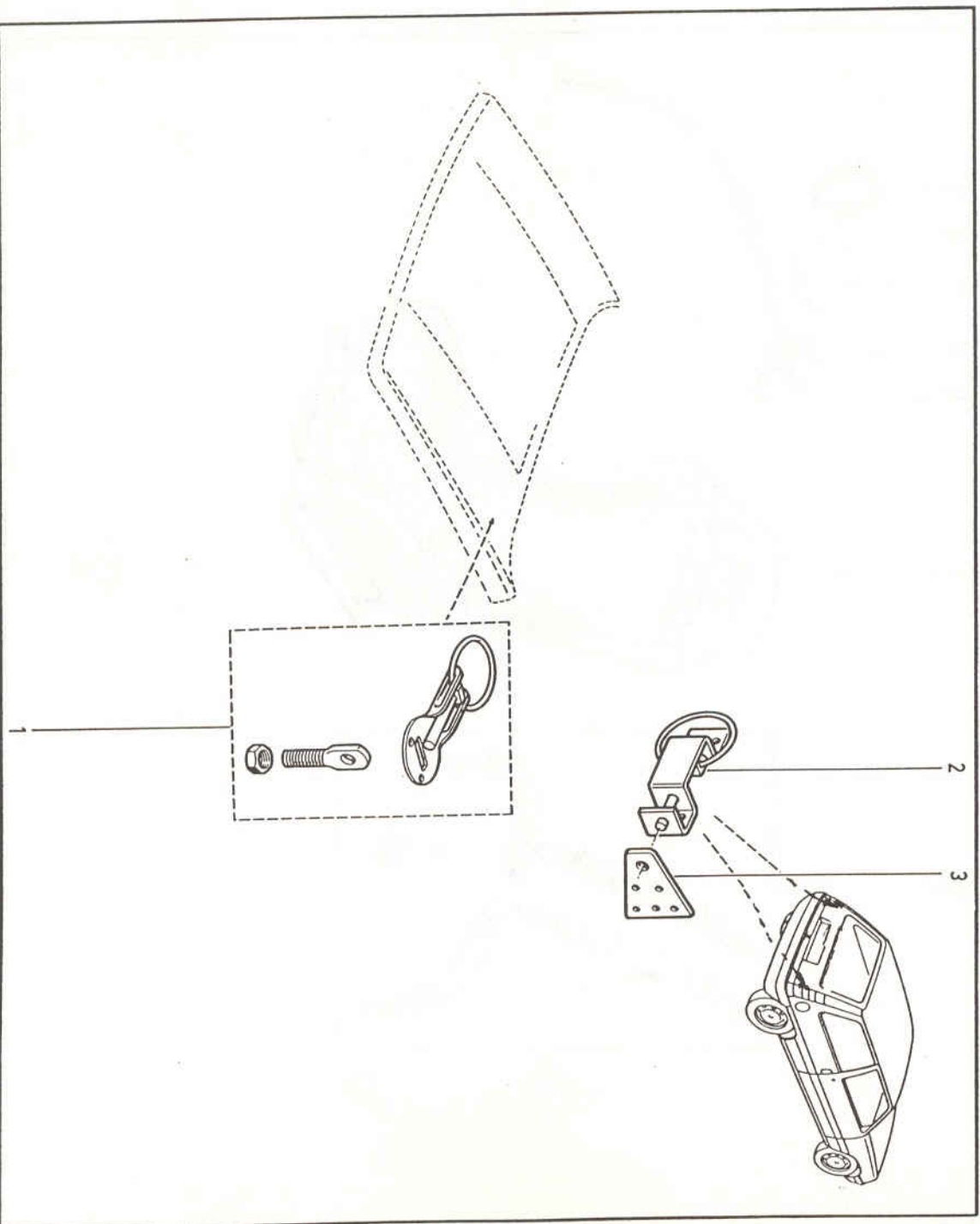

- 1 - 77 11 065 775 ▲
- 2 - 77 11 067 212 ▲
- 3 - 77 11 067 215 ▲

RENAULT 5 GT TURBO groupe A

48.01



- 1 - 77 11 065 775 ▲
- 2 - 77 11 067 212 ▲
- 3 - 77 11 067 215 ▲

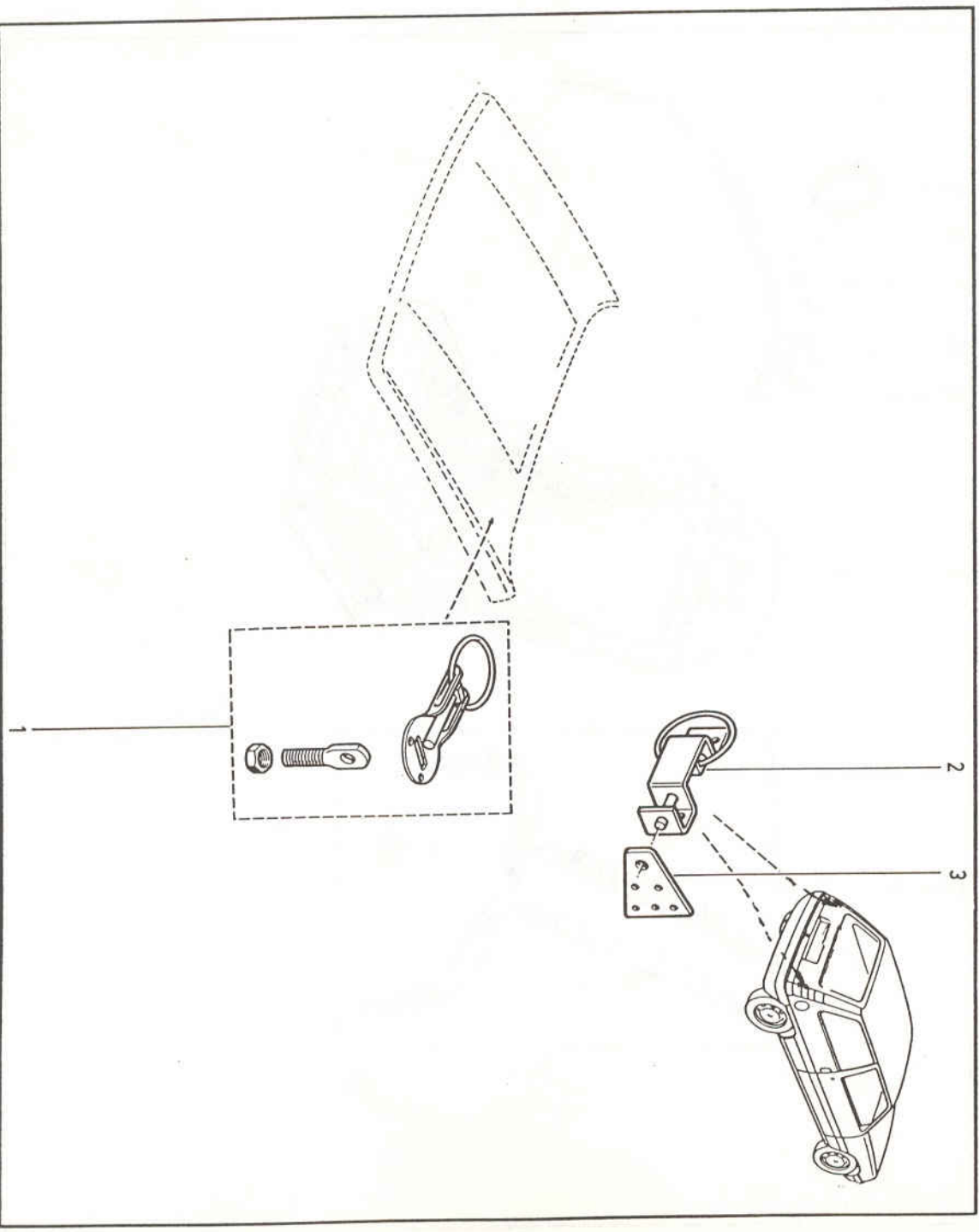

RENAULT 5 GT TURBO groupe A

77.10

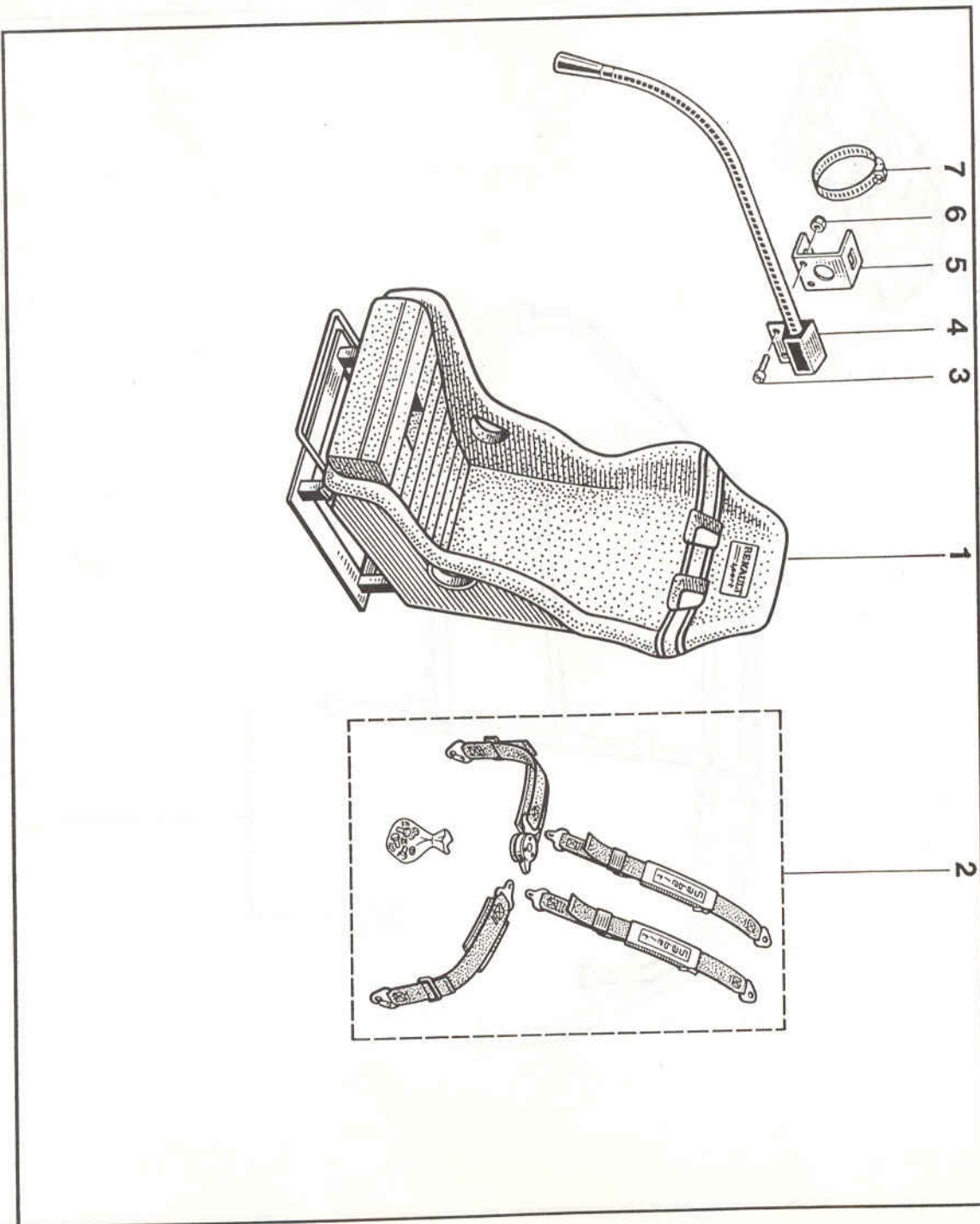

- 1 - 77 11 067 454 ▲
- 2 - 77 11 067 268 ▲
- 3 - 77 11 065 333 ▲
- 4 - 77 11 065 883 ▲
- 5 - 77 11 065 882 ▲
- 6 - 77 11 065 770 ▲
- 7 - 77 03 083 004

RENAULT 5 GT TURBO groupe A

81.00



1 - 60 00 007 919 Acier (Devil) ▲
77 11 066 639 Alu (Matter) ▲
77 11 068 324 Acier (Matter) ▲
à souder sur la caisse

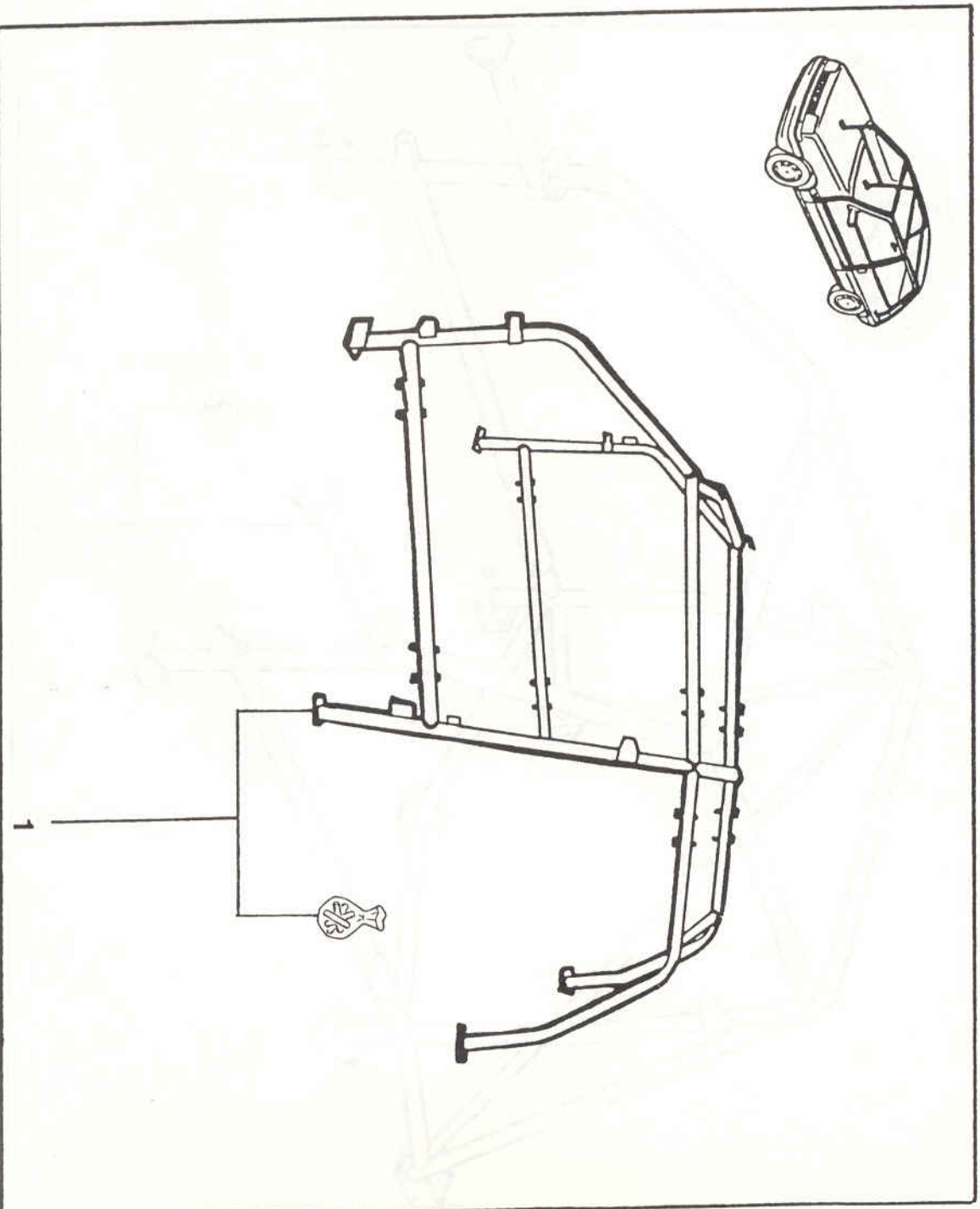

I - 77 11 066 936 Alu (Matter) ▼

RENAULT 5 GT TURBO groupe A

81.10

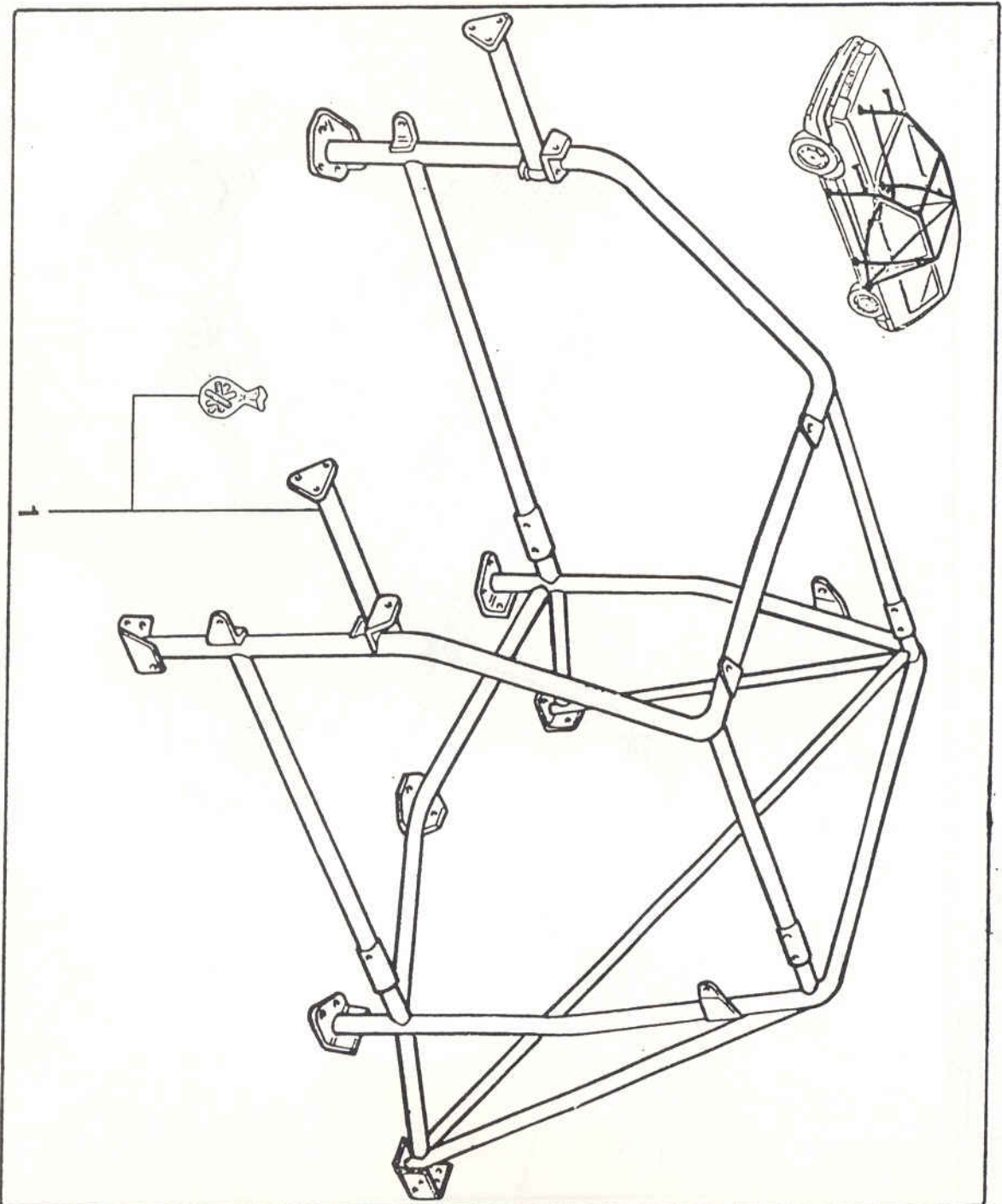

RENAULT 5 GT TURBO GROUPE A

83.01



- 1 - 77 11 068 175 ▲
- 2 - 77 03 083 057

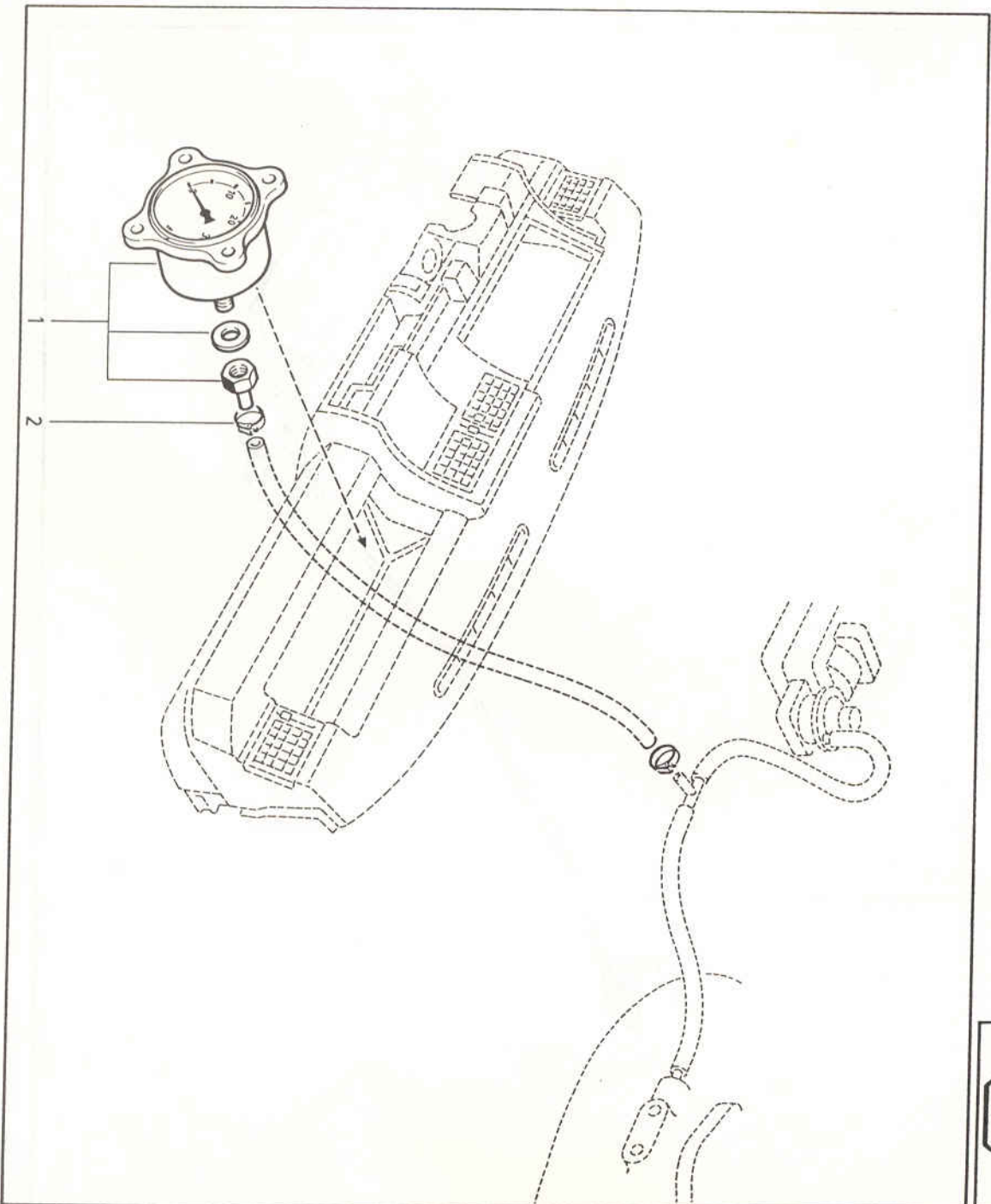

1 - 77 11 066 603 ▲
2 - 77 11 066 512 ▲

RENAULT 5 GT TURBO groupe A

83.02

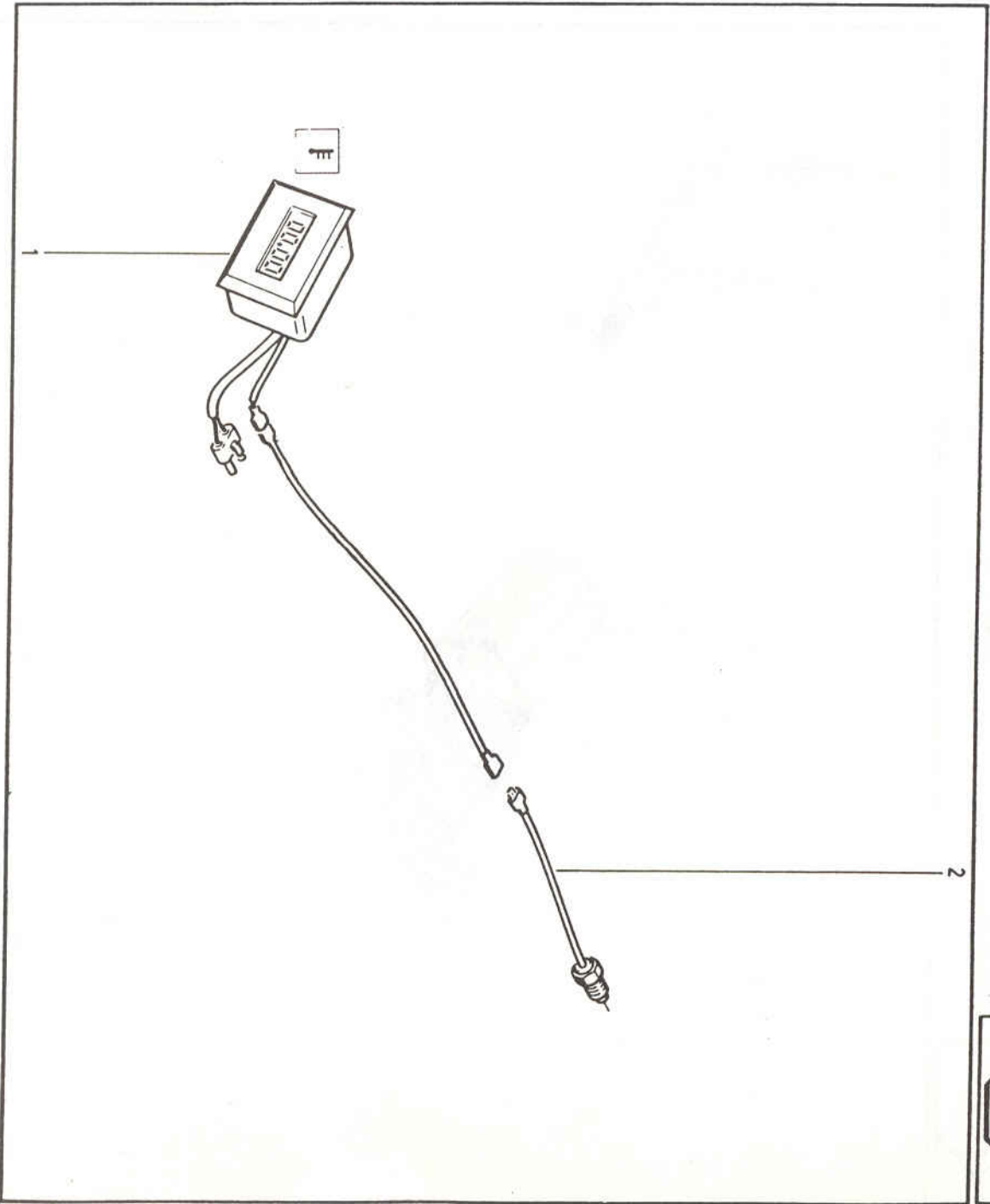

RENAULT 5 GT Turbo groupe A

85.23

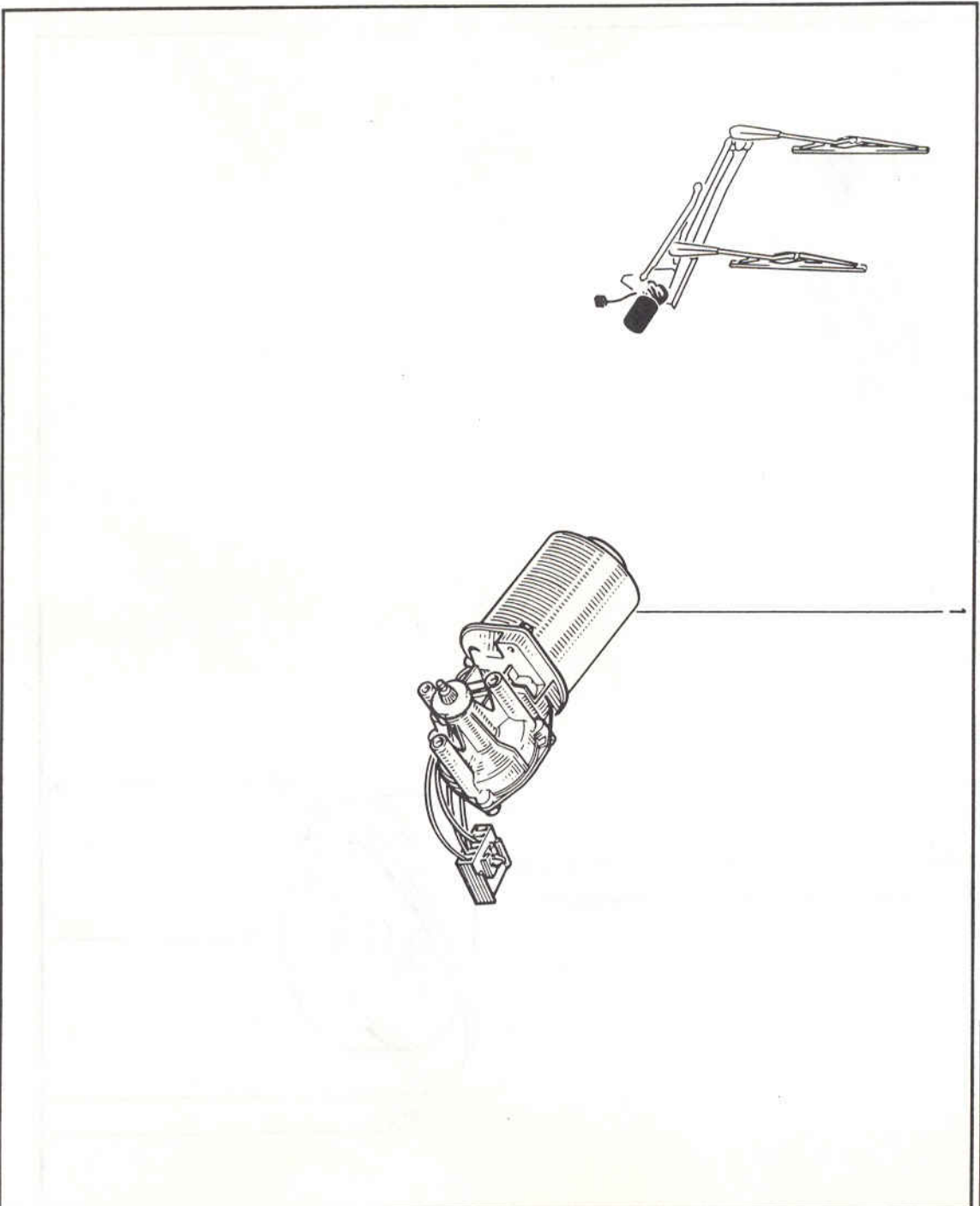

RENAULT 5 GT TURBO groupe A

90.01

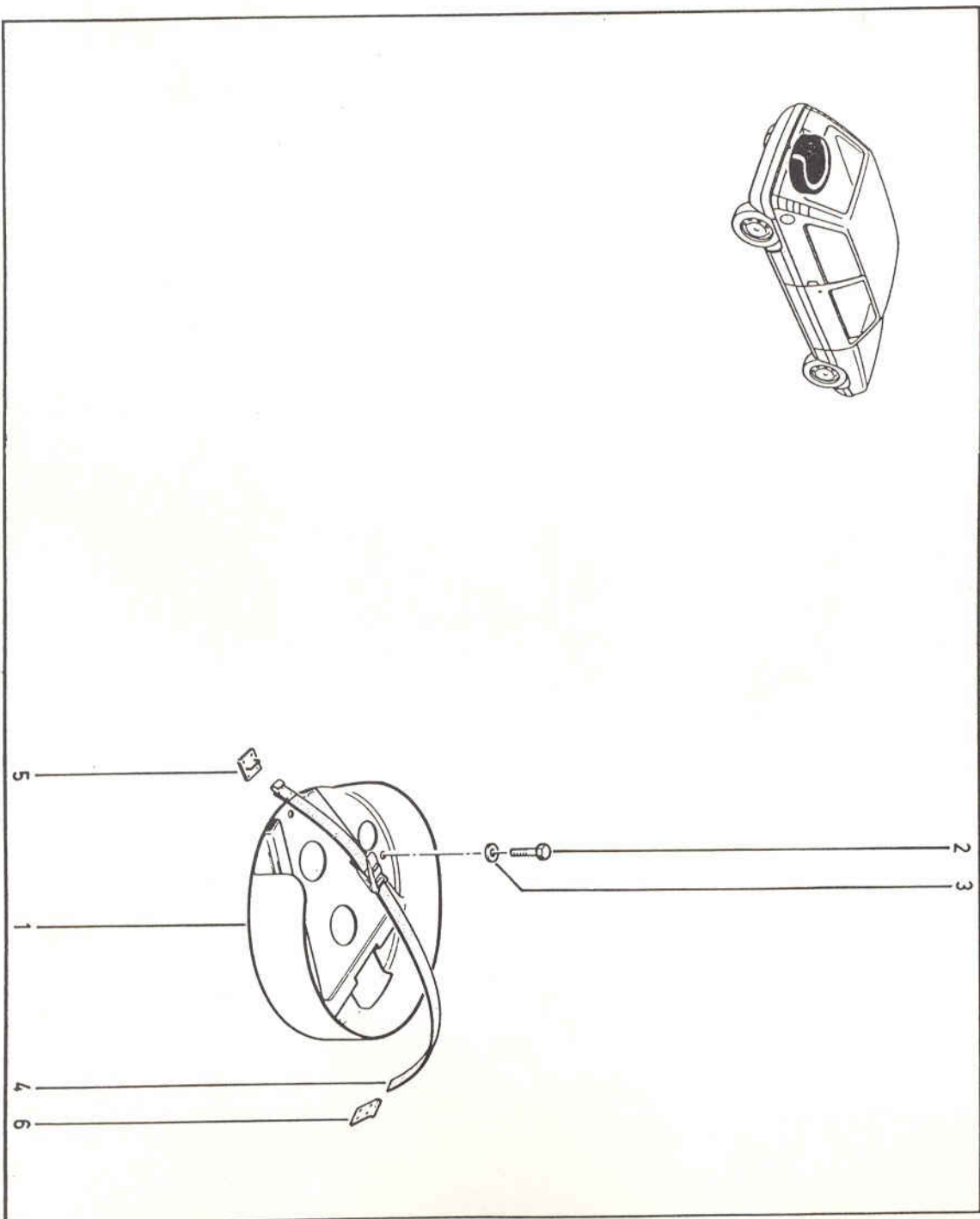
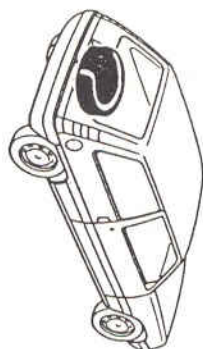

- 1 - 77 11 066 748 ▲
- 2 - 60 01 009 036
- 3 - 79 02 057 013
- 4 - 77 11 065 835 ▲
- 5 - 77 11 064 572 ▲
- 6 - 77 11 064 574 ▲

Kit 1

- 1 - 77 11 064 029 ▲
- 2 - 60 01 003 024 ▲
- Repère vert Ø 75,905 à 75,915
- Repère bleu Ø 75,915 à 75,925
- Repère rouge Ø 75,925 à 75,935
- 3 - 77 00 502 511
- 4 - 06 07 777 500
- 5 - 60 01 000 207 ▲
- 6 - 77 00 612 591
- 7 - 77 00 575 994

RENAULT 5 GT TURBO groupe A

10.20

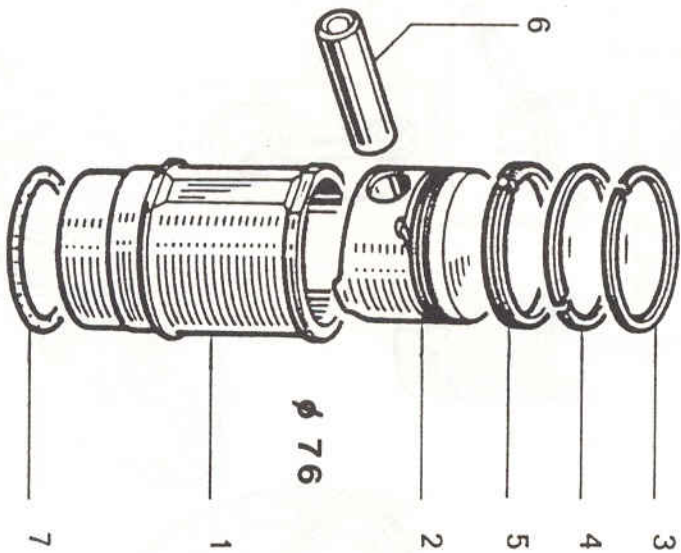

Kit 2

- 1 - 77 11 067 322 ▲
- 2 - 77 11 067 275 ▲
- 3 - 77 11 066 552 ▲
- 4 - 77 11 066 606 ▲ (ép : 3)
- 5 - 77 11 066 605 ▲ (ép : 1,75)
- 6 - 77 11 066 607 ▲ (ép : 1,5)
- 7 - 77 11 066 604 ▲
- 8 - 77 11 064 025 ▲

RENAULT 5 GT TURBO groupe A

10.60

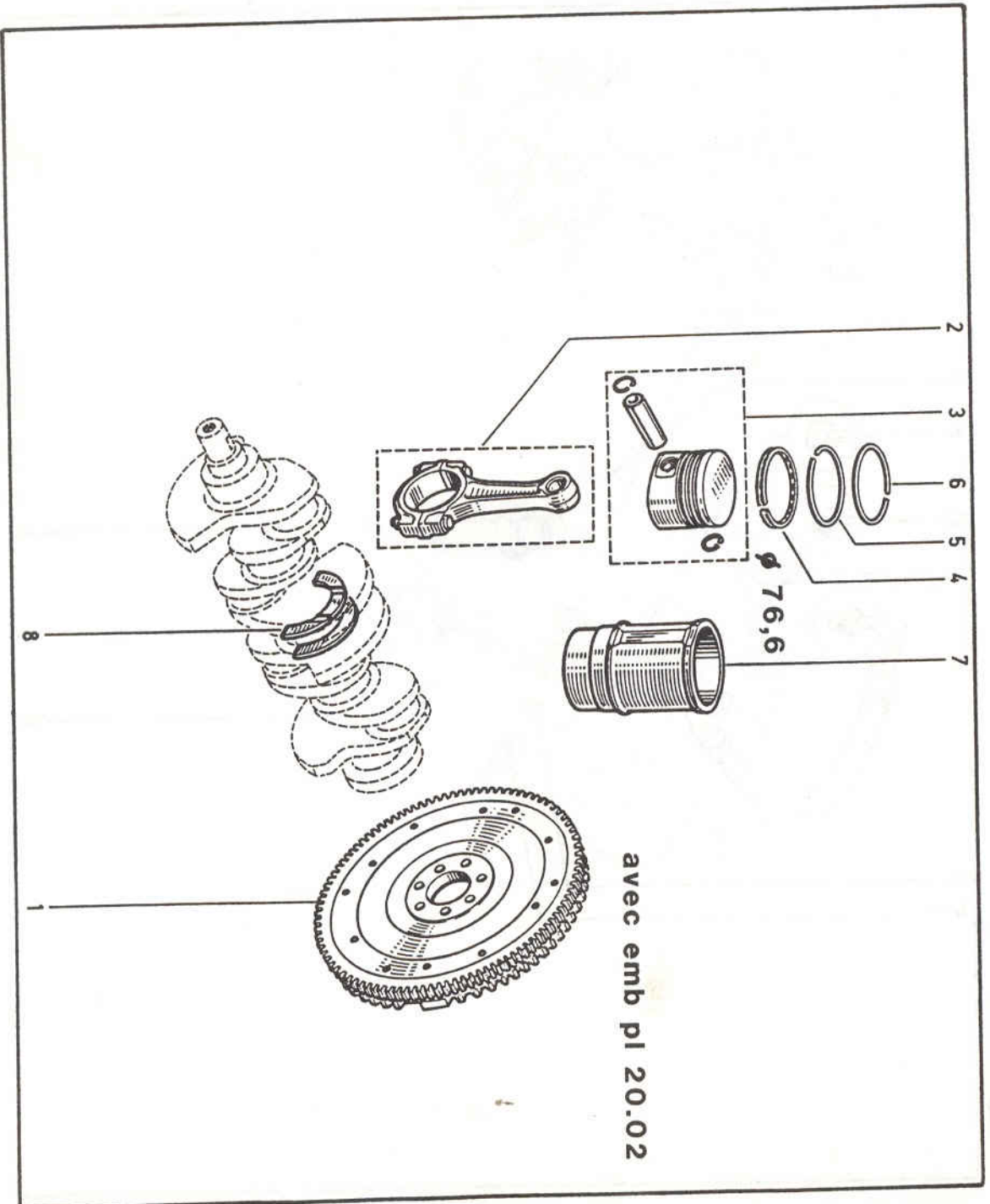

- 1 - 60 01 008 132 ▲
- 2 - 60 01 007 136 ▲
- 3 - 77 00 690 542
- 4 - 77 03 062 025
- 5 - 77 00 644 703 ▲
- 6 - 60 01 022 212
- 7 - 77 01 031 501
- 8 - 60 01 021 216 ▲

RENAULT 5 GT TURBO groupe A

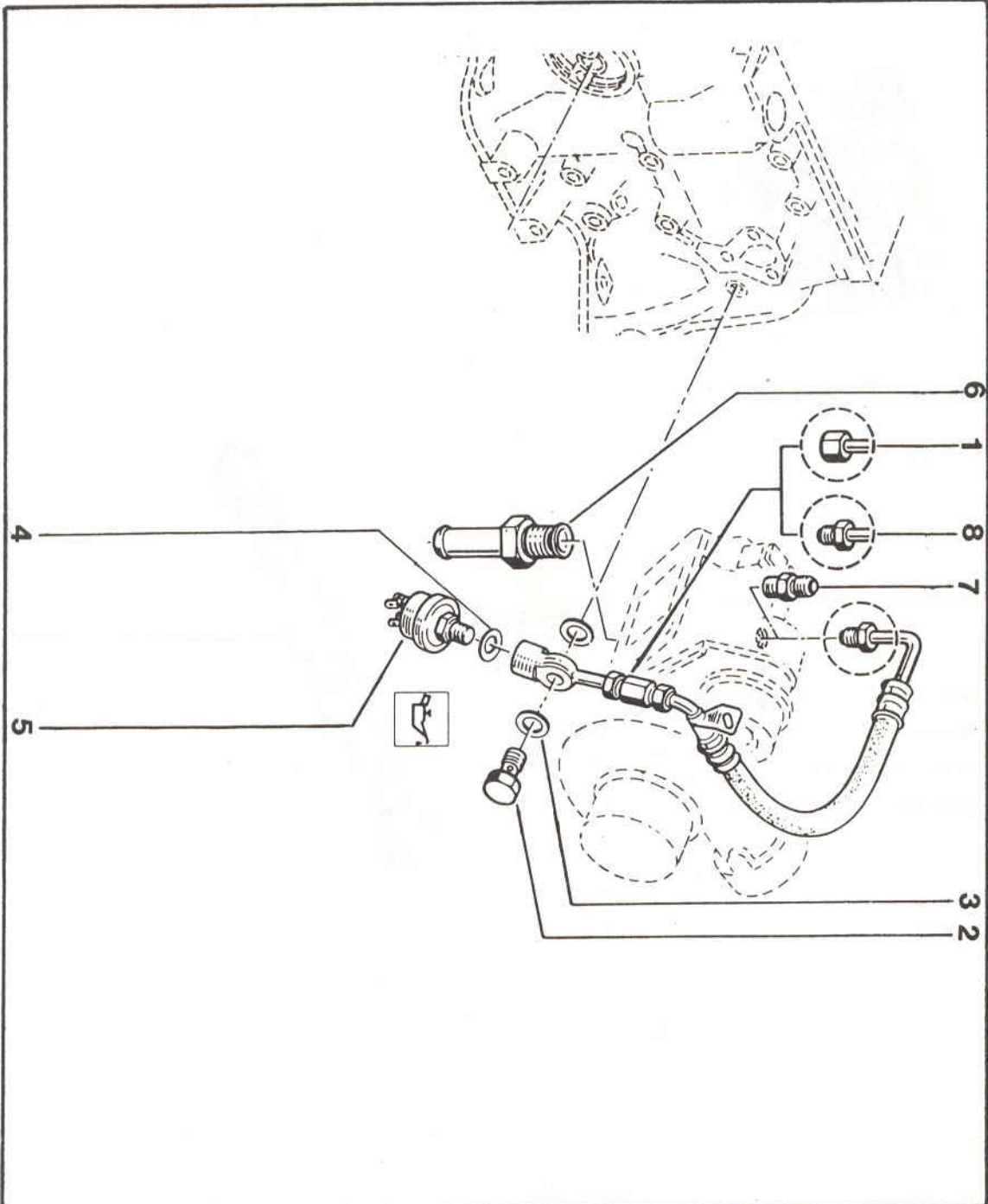
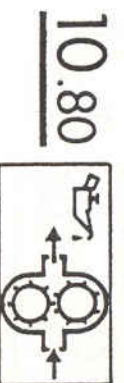

RENAULT 5 GT TURBO groupe A

- 1 - 77 11 067 204 Kit 1 et 2 ▲
- 2 - 77 11 066 550 Kit 2 ▲
- 60 01 009 260 Kit 1 ▲
- 3 - 77 11 066 551 Kit 2 ▲
- 60 01 009 259 Kit 1 ▲
- 4 - 77 00 655 195 Kit 1 et 2 ▲
- 5 - 77 11 066 739 Kit 1 et 2 ▲
- 6 - 77 11 066 676 Kit 1 et 2 ▲

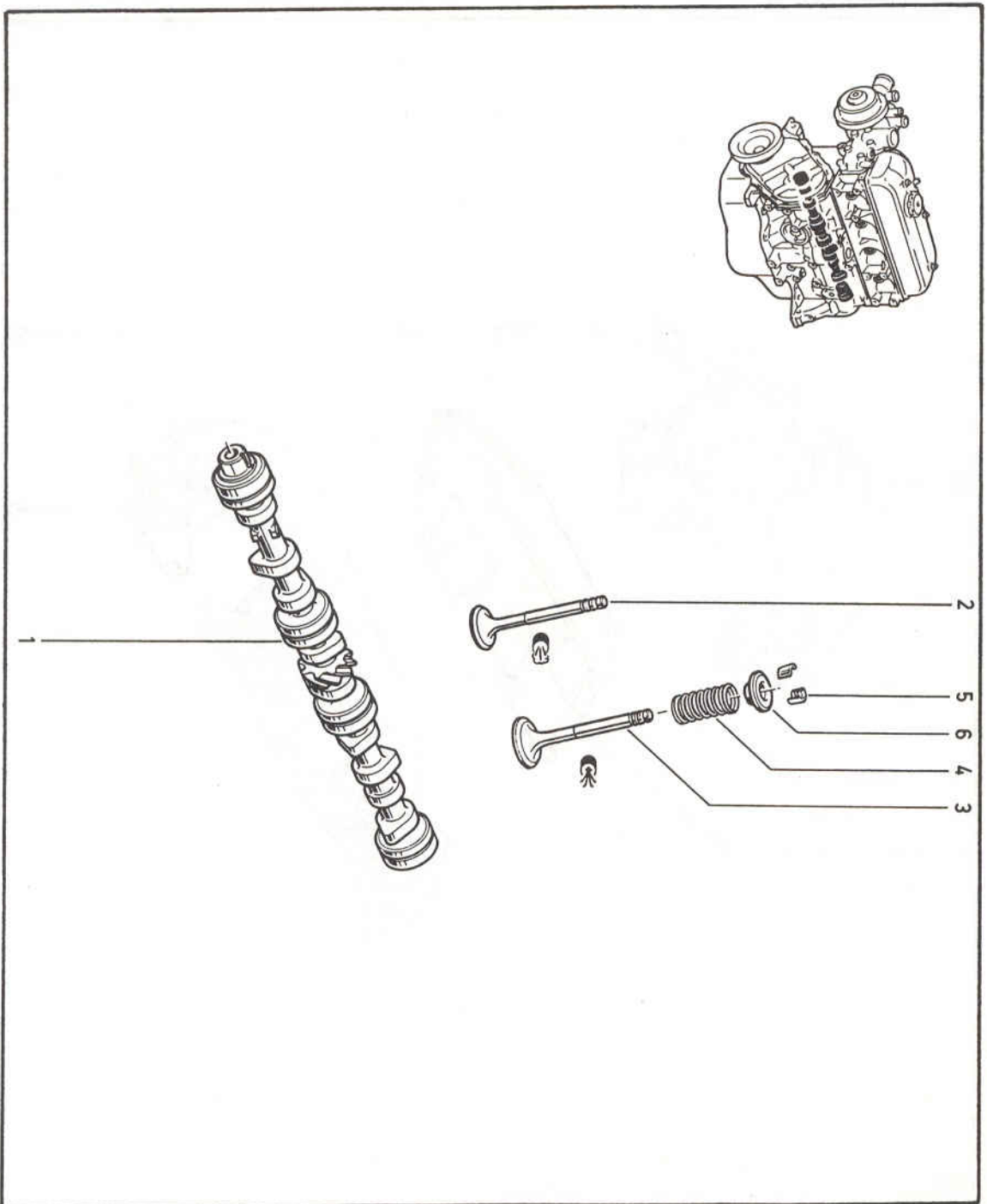

- 1 - 77 11 066 879 ▲
- 2 - 77 11 066 984 ▲
- 3 - 60 01 009 270
- 4 - 60 01 008 146

RENAULT 5 GT TURBO groupe A

12.02

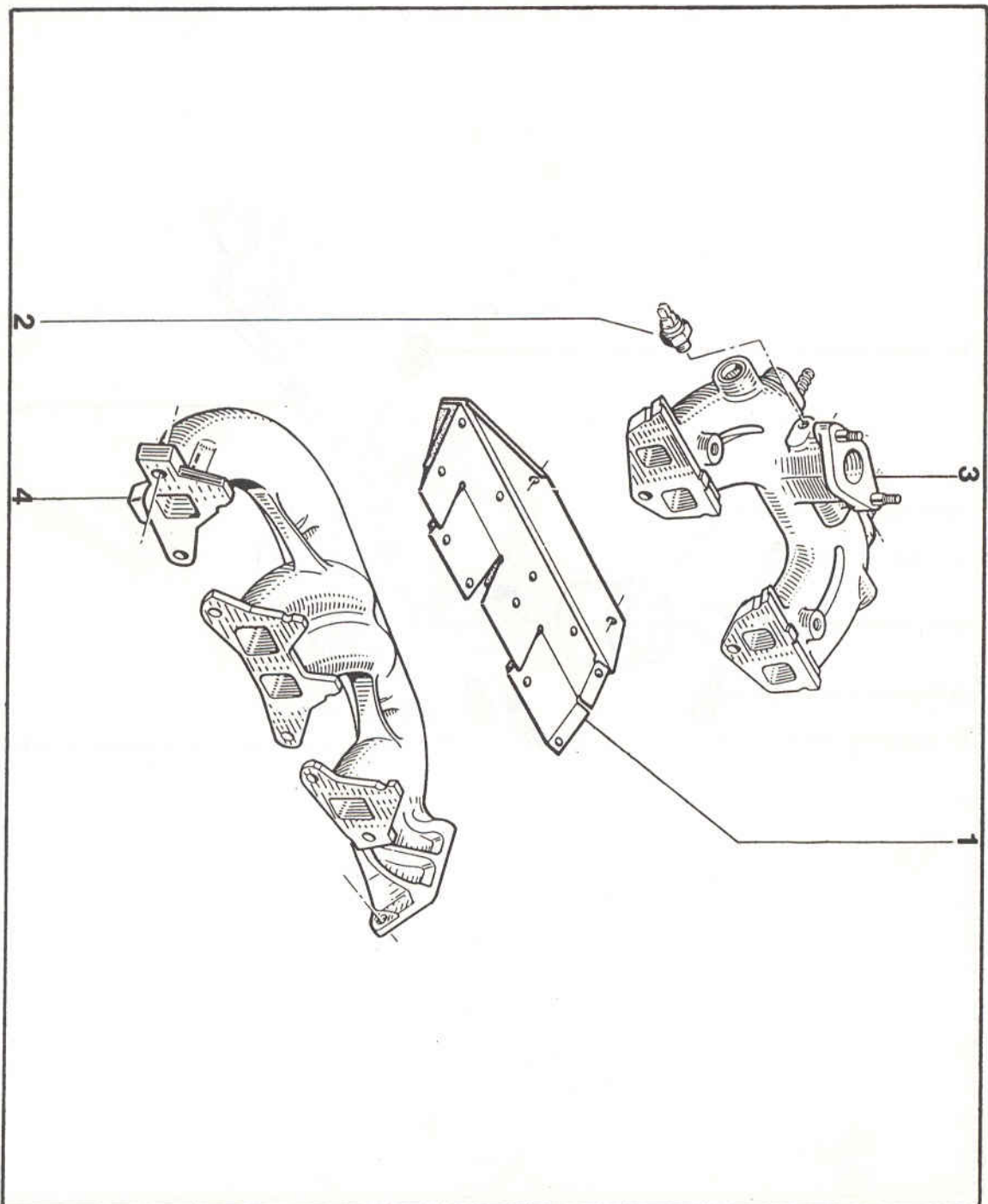

1 -	77	11	067	239	▲
2 -	77	11	067	241	▲
3 -	77	11	067	240	▲
4 -	77	11	067	238	▲
5 -	77	11	067	243	▲
6 -	77	11	067	245	▲
7 -	77	11	067	244	▲
8 -	77	11	067	242	▲

RENAULT 5 GT TURBO groupe A

12.12

